



EUROPEAN MEDICINES AGENCY
SCIENCE MEDICINES HEALTH

14 October 2021
EMA/619369/2021
Committee for Medicinal Products for Human Use (CHMP)

Assessment report

Trydonis

International non-proprietary name: beclometasone dipropionate /
formoterol fumarate dihydrate / glycopyrronium

Procedure No. EMEA/H/C/004702/X/0015

Note

Variation assessment report as adopted by the CHMP with all information of a commercially confidential nature deleted.



Table of contents

1. Background information on the procedure	6
1.1. Submission of the dossier.....	6
1.2. Legal basis	6
1.3. Information on Paediatric requirements.....	6
1.4. Information relating to orphan market exclusivity.....	6
1.4.1. Similarity.....	6
1.5. Scientific advice	6
1.6. Steps taken for the assessment of the product.....	6
2. Scientific discussion	7
2.1. Problem statement	7
2.1.1. Disease or condition.....	7
2.1.2. Epidemiology	7
2.1.3. Aetiology and pathogenesis	8
2.1.4. Clinical presentation, diagnosis and stage.....	8
2.1.5. Management.....	8
2.2. About the product	9
2.3. Type of Application and aspects on development.....	10
2.4. Quality aspects	12
2.4.1. Introduction.....	12
2.4.2. Active substances.....	13
2.4.3. Finished medicinal product.....	14
2.4.4. Discussion on chemical, and pharmaceutical aspects.....	20
2.4.5. Conclusions on the chemical, pharmaceutical and biological aspects	20
2.5. Non-clinical aspects	20
2.5.1. Introduction.....	20
2.5.2. Pharmacology	21
2.5.3. Pharmacokinetics.....	21
2.5.4. Toxicology	21
2.5.5. Ecotoxicity/environmental risk assessment	28
2.5.6. Discussion on non-clinical aspects.....	30
2.5.7. Conclusion on the non-clinical aspects.....	32
2.6. Clinical aspects	32
2.6.1. Introduction.....	32
2.6.2. Clinical pharmacology	34
2.6.3. Discussion on clinical pharmacology.....	37
2.6.4. Conclusions on clinical pharmacology	39
2.6.5. Clinical efficacy	40
2.6.6. Discussion on clinical efficacy.....	54
2.6.7. Conclusions on the clinical efficacy.....	59
2.6.8. Clinical safety.....	59
2.6.9. Discussion on clinical safety	63
2.6.10. Conclusions on the clinical safety	65
2.7. Risk Management Plan	65

2.7.1. Safety concerns.....	65
2.7.2. Pharmacovigilance plan	65
2.7.3. Risk minimisation measures	66
2.7.4. Conclusion	66
2.8. Pharmacovigilance.....	66
2.8.1. Pharmacovigilance system	66
2.8.2. Periodic Safety Update Reports submission requirements	66
2.9. Product information	66
2.9.1. User consultation	66
3. Benefit-Risk Balance.....	67
3.1. Therapeutic Context	67
3.1.1. Disease or condition.....	67
3.1.2. Available therapies and unmet medical need	67
3.1.3. Main clinical studies	67
3.2. Favourable effects	67
3.3. Uncertainties and limitations about favourable effects	68
3.4. Unfavourable effects.....	69
3.5. Uncertainties and limitations about unfavourable effects	69
3.6. Effects Table.....	70
3.7. Benefit-risk assessment and discussion	70
3.7.1. Importance of favourable and unfavourable effects	70
3.7.2. Balance of benefits and risks.....	71
3.7.3. Additional considerations on the benefit-risk balance	71
3.8. Conclusions	71
4. Recommendations	71

List of abbreviations

* This is a general list of abbreviations. Not all abbreviations are used in this Assessment report.

ADR	Adverse drug reaction
AE	Adverse event
Al	Aluminium
ANCOVA	Analysis of covariance
ANOVA	Analysis of variance
BDI	Baseline dyspnoea index
BDP	Beclometasone dipropionate
BfArM	Bundesinstitut für Arzneimittel und Medizinprodukte
bid	Twice daily
BMI	Body mass index
BP	Blood pressure
bpm	Beats per minute
CAT	COPD assessment test
CEP	Certificate of suitability from the European Pharmacopoeia
CHMP	Committee for Medicinal Products for Human Use
CI	Confidence interval
COPD	Chronic obstructive pulmonary disease
CRF	Case report form
CS	Clinically significant
CSR	Clinical study report
DBP	Diastolic blood pressure
DD	Delivered dose
DDI	Drug-drug interaction
DoE	Design of experiments
DPI	Dry powder inhaler
DUSA	Dosage Unit Sampling Apparatus
ECG	Electrocardiogram
eCRF	Electronic case report form
eFPF	Extra-fine particle fraction
EMA	European Medicines Agency
E-RS	Exacerbations of chronic pulmonary disease tool-respiratory symptoms
EU	European Union
FDC	Fixed dose combination
FEV ₁	Forced expiratory volume in 1 second
FF	Formoterol fumarate
FMEA	Failure mode and effects analysis
FPF	Fine particle fraction
FPM	Fine particle mass
FTA	Fault tree analysis
FVC	Forced vital capacity
GB	Glycopyrronium bromide
GCP	Good Clinical Practice
GOLD	Global Initiative for Chronic Obstructive Lung Disease
γGT	Gamma-glutamyltransferase
HFA	Hydroxyfluoroalkane
HPLC	High performance liquid chromatography
HR	Heart rate
IC	Inspiratory capacity

ICH	International Conference on Harmonisation
ICP-MS	Inductively coupled plasma mass spectrometry
ICS	Inhaled corticosteroid
IND	Indacaterol
IRS	Interactive response system
ITT	Intent-to-treat
i.v.	Intravenous
LABA	Long-acting β_2 -agonist
LAMA	Long-acting muscarinic antagonist
LOCF	Last observation carried forward
MAA	Marketing authorisation application
MACE	Major adverse cardiovascular event
MCID	Minimal clinically important difference
MD	Metered dose
MMAD	Mass median aerodynamic diameter
MMRM	Mixed model for repeated measures
NA	Not applicable
NCS	Non-clinically significant
NGI	New generation impactor
od	Once daily
OIP	Orally inhaled products
PA	Polyamide
PD	Pharmacodynamic
PE	Point estimate
PE	Polyethylene
PET	Polyethylene-Terephthalate
Ph. Eur.	European Pharmacopoeia
PK	Pharmacokinetic
pMDI	Pressurised metered dose inhaler
PP	Per protocol
PT	Preferred term
QbD	Quality by design
QoL	Quality of life
QTcF	Fridericia-corrected QT interval
QTcP	Population-corrected QT interval
QTTP	Quality target product profile
RI	Renal impairment
SABA	Short-acting β_2 -agonist
SBP	Systolic blood pressure
SD	Standard deviation
SGRQ	St George's Respiratory Questionnaire
SmPC	Summary of Product Characteristics
SOC	System organ class
SS	Steady-state
TDI	Transition dyspnoea index
TEAE	Treatment-emergent adverse event
TQT	Thorough QT
UPLC	Ultra performance liquid chromatography
UV	Ultra violet
vs.	Versus

1. Background information on the procedure

1.1. Submission of the dossier

Chiesi Farmaceutici S.p.A. submitted on 21 May 2021 an extension of the marketing authorisation.

The MAH applied for the addition of a new pharmaceutical form (inhalation powder) associated with a new strength (88µg / 5µg / 9µg). The RMP (version 7.1) is updated in accordance.

1.2. Legal basis

The legal basis for this application refers to:

Article 19 of Commission Regulation (EC) No 1234/2008 and Annex I of Regulation (EC) No 1234/2008, (2) points (c) (d) - Extensions of marketing authorisation.

1.3. Information on Paediatric requirements

Pursuant to Article 8 of Regulation (EC) No 1901/2006, the application included an EMA Decision CW/0001/2015 on the granting of a class waiver.

1.4. Information relating to orphan market exclusivity

1.4.1. Similarity

Pursuant to Article 8 of Regulation (EC) No. 141/2000 and Article 3 of Commission Regulation (EC) No 847/2000, the MAH did not submit a critical report addressing the possible similarity with authorised orphan medicinal products because there is no authorised orphan medicinal product for a condition related to the proposed indication.

1.5. Scientific advice

The MAH did seek Scientific advice at the CHMP (EMA/H/SA/3068/1/2015/III, EMA/CHMP/SAWP/432923/2017).

1.6. Steps taken for the assessment of the product

The Rapporteur and Co-Rapporteur appointed by the CHMP were:

Rapporteur: Janet Koenig Co-Rapporteur: N/A

The Rapporteur appointed by the PRAC was:

PRAC Rapporteur: Jan Neuhauser

The application was received by the EMA on	21 May 2021
The procedure started on	17 June 2021

The CHMP Rapporteur's first Assessment Report was circulated to all CHMP and PRAC members on	6 September 2021
The PRAC Rapporteur's first Assessment Report was circulated to all PRAC and CHMP members on	14 September 2021
The PRAC agreed on the PRAC Assessment Overview and Advice to CHMP during the meeting on	30 September 2021
The CHMP, in the light of the overall data submitted and the scientific discussion within the Committee, issued a positive opinion for granting or granting an extension of the marketing authorisation to Trydonis on	14 October 2021

2. Scientific discussion

2.1. Problem statement

The purpose of this application is to add a new pharmaceutical form (inhalation powder) associated with a new strength (88µg / 5µg / 9µg) for the currently approved COPD indication. Trydonis is a multiple of Trimbow for which the same line extension application was approved by CHMP (EMA/H/C/004257/X/0012).

2.1.1. Disease or condition

Trydonis is currently approved for the treatment of adult patients with chronic obstructive pulmonary disease (COPD) with specific risk factors.

Chronic obstructive pulmonary disease is an inflammatory disease of the airways characterised by a progressive decline in lung function that is accompanied by cough, excess sputum production and breathlessness [Lopez et al., 2006¹], [Mathers and Loncar, 2006²]. Pharmacologic therapy for COPD aims to reduce symptoms, exacerbations frequency and severity, and improve exercise tolerance and overall health status [Tashkin et al., 2008³].

2.1.2. Epidemiology

COPD is strongly linked to tobacco smoking, particularly cigarette smoking and is a male predominant condition. In COPD clinical trials in developed countries generally about two thirds of included patients are male and for both males and females the average age tends to be in the early sixties. In poor countries the male predominance is not as marked as women may develop COPD as a result of cooking over open fires. The prevalence is quite variable on a local basis with higher prevalence linked to lower affluence and social status. Screening would be possible by mass measurement of lung function, which is cheap, easy, and non-invasive, but is not done in practice. There have been no substantial trials of the value of screening for COPD. Tobacco smoking cessation or non/never smoking is an effective measure and societal efforts have been made in that direction rather than into screening programmes.

¹ Lopez AD, Shibuya K, Rao C, et al. Chronic obstructive pulmonary disease: current burden and future projections. *Eur Respir J.* 2006;27(2):397-412.

² Mathers CD and Loncar D. Projections of global mortality and burden of disease from 2002 to 2030. *PLoS Med.* 2006;3(11):e442.

³ Tashkin DP, Celli B, Senn S, et al. A 4-year trial of tiotropium in chronic obstructive pulmonary disease. *N Engl J Med.* 2008;359(15):1543-54.

COPD is a major public health problem and is the fourth leading cause of death in the world, with increasing prevalence and mortality predicted in the coming decades. COPD is projected to be the third leading cause of death by 2020 [GOLD 2020].

2.1.3. Aetiology and pathogenesis

The chronic airflow limitation that is characteristic of COPD is caused by a mixture of small airway disease (e.g. obstructive bronchiolitis) and parenchymal destruction (emphysema). The relative contributions vary from person to person and evolve at different rates over time. Chronic inflammation causes structural changes, narrowing of the small airways and destruction of the lung parenchyma leading to the loss of alveolar attachments to the small airways and decreased lung elastic recoil.

The main risk factor for COPD is tobacco smoking. However, other environmental exposures such as biomass fuel exposure and air pollution may also contribute. Host factors (e.g. genetic abnormalities, abnormal lung function and accelerated aging) predispose individuals to develop COPD.

2.1.4. Clinical presentation, diagnosis and stage

COPD is characterised by cough, dyspnoea on exertion or even at rest, with a consequent reduction of physical activity and deterioration of quality of life (QoL) [GOLD 2020]. The inflammatory response contributes to small airways disease (e.g. obliterative bronchiolitis) and emphysema, which in turn reduce the elastic recoil of the lungs leading to collapse and obstruction of the small airways during exhalation. Systemic features of COPD are very common [Barnes PJ and Celli BR 2009] and their evaluation allows a more accurate prediction of mortality risk and comorbidity risk than lung function alone [Cote CG et al., 2007], [De Torres JP et al., 2009], [Puhan MA et al., 2009].

During the natural course of COPD, the majority of patients develop acute episodes of worsening of symptoms that differ from the day to day variations and may require modifications in therapy (GOLD 2019). These episodes are referred to as exacerbations. COPD exacerbations are important because they are associated with accelerated FEV₁ decline [Donaldson GC et al., 2002], significant morbidity, healthcare cost and mortality [Celli BR and Barnes PJ, 2007].

According to the Global Initiative for Chronic Obstructive Lung Disease document [GOLD 2020], the assessment of the disease severity should take into account various aspects of the disease such as symptoms, degree of airflow limitation, exacerbation risk and comorbidities. Based on the overall disease severity, COPD patients can be divided into the following four groups:

- Group A (i.e. patients with low risk [of future events such as exacerbations, hospital admissions or death] and less symptoms);
- Group B (i.e. patients with low risk and more symptoms);
- Group C (i.e. patients with high risk and less symptoms);
- Group D (i.e. patients with high risk and more symptoms).

2.1.5. Management

Currently, the main treatment options for patients with COPD belong to a restricted number of pharmacological classes including bronchodilators (short-acting β 2-agonists [SABAs] and long-acting β 2agonists [LABAs]), antimuscarinics (short-acting muscarinic antagonists [SAMAs] and long-acting muscarinic antagonists [LAMAs]), and inhaled corticosteroids (ICS). Phosphodiesterase-4 (PDE-4)

inhibitors are a relatively new class of medicines that combine a dual albeit limited bronchodilator and anti-inflammatory effect [Vogelmeier et al., 2017⁴].

The GOLD document recommends the use of one or more long-acting bronchodilators as maintenance therapy for the treatment and management of COPD [GOLD, 2020⁵]. A number of studies have shown that combining bronchodilators of different pharmacologic classes may improve lung function compared with bronchodilators used as monotherapies [Cazzola et al., 2004a⁶], [Brashier et al., 2005⁷], [Cazzola et al., 2005⁸]. Such combinations of bronchodilators with different mechanisms and duration of action may increase the degree of bronchodilation leading to better symptom control. ICS are highly effective as anti-inflammatory treatments in respiratory diseases and maintenance treatment with ICS is routinely used in association with LABAs for patients with a history of exacerbations despite treatment with long-acting bronchodilators. Such ICS/LABA combinations may be the first choice of initial therapy in some patients, such as those with a history and/or finding suggestive of asthma-COPD overlap syndrome (ACOS) [GINA, 2019⁹].

The triple combination therapy of inhaled ICS, LABA and LAMA, has become an option for maintenance treatment of COPD and as a "step-up" therapy from double combination therapies. Moreover, since the components of triple therapy have different and complementary molecular mechanisms of action, there is a logical rationale for the use of these drugs together leading to enhanced clinical benefits [Cazzola et al., 2004b¹⁰], [van Noord et al., 2005¹¹]. Indeed, when patients remain symptomatic with dual therapies, the combination of all three classes (ICS, LABA and LAMA) is recommended (as a rational escalation of pharmacological management).

2.2. About the product

Trydonis 88/5/9 Dry Powder Inhaler (DPI), hereafter also referred to as CHF 5993 DPI, is a triple fixed dose combination (FDC) of the inhaled corticosteroid (ICS) beclometasone dipropionate (BDP), the long-acting β 2-agonist (LABA) formoterol fumarate dihydrate (FF) and the long-acting muscarinic antagonist (LAMA) glycopyrronium bromide (GB), developed by the MAH.

CHF 5993 was first developed for COPD and first formulated to be delivered via a pressurised metered dose inhaler (pMDI). On 22 February 2018, the CHMP adopted a positive opinion, recommending the granting of a MA for Trydonis pMDI, intended for the maintenance treatment of moderate to severe chronic obstructive pulmonary disease (COPD). The approved posology is two inhalations of Trydonis twice daily (i.e. total daily dose: 400 μ g BDP, 24 μ g FF, 50 μ g GB).

⁴ Vogelmeier CF, Criner GJ, Martinez FJ, et al. Global Strategy for the Diagnosis, Management, and Prevention of Chronic Obstructive Lung Diseases 2017 Report: GOLD Executive Summary. *Eur Respir J.* 2017;49(3):1700214.

⁵ Global Initiative for Chronic Obstructive Lung Disease (GOLD): global strategy for the diagnosis, management and prevention of COPD. 2020 update. Available at: www.goldcopd.org.

⁶ Cazzola M, Centanni S, Santus P, et al. The functional impact of adding salmeterol and tiotropium in patients with stable COPD. *Respir Med.* 2004a;98(12):1214-21.

⁷ Brashier B, Jantikar A, Maganji M., et al. Addition of formoterol to tiotropium produces better FEV1 and FVC responses when measured over 24 hours following single-dose administration in subjects with moderate-to-severe COPD. *Chest.* 2005;128(4_MeetingAbstracts):258s.

⁸ Cazzola M, Noschese P, Salzillo A, et al. Bronchodilator response to formoterol after regular tiotropium or to tiotropium after regular formoterol in COPD patients. *Respir Med.* 2005;99(5):524-8.

⁹ Global Initiative for Asthma (GINA): global strategy for asthma management and prevention. 2019 update. Available at: www.ginasthma.org.

¹⁰ Cazzola M, Di Marco F, Santus P, et al. The pharmacodynamic effects of single inhaled doses of formoterol, tiotropium and their combination in patients with COPD. *Pulm Pharmacol Ther.* 2004b;17(1):35-9.

¹¹ van Noord JA, Aumann JL, Janssens E, et al. Comparison of tiotropium once daily, formoterol twice daily and both combined once daily in patients with COPD. *Eur Respir J.* 2005;26(2):214-22.

2.3. Type of Application and aspects on development

In the present application, the MAH seeks to add a different formulation of Trydonis, namely an inhalation powder delivered by means of a multi-dose breath-actuated Dry Powder Inhaler (DPI). The same device is currently marketed in Europe for the administration of the MAH's dual FDC CHF 1535 inhalation powder (Foster NEXThaler and other tradenames), containing BDP 100 µg/inhalation and FF 6 µg/inhalation.

Trydonis DPI is intended to be used in the same COPD indication as Trydonis pMDI and at same doses (2 inhalations bid):

"Maintenance treatment in adult patients with moderate to severe chronic obstructive pulmonary disease (COPD) who are not adequately treated by a combination of an inhaled corticosteroid and a long-acting beta2 agonist or a combination of a long-acting beta2 agonist and a long-acting muscarinic antagonist (for effects on symptoms control and prevention of exacerbations see section 5.1)".

The device consists of a casework comprising a lower shell (1) with window to display dose counting numbers (2) and an integral cover (3), with cover retention clips (3a) to hold the cover (3) in the closed position during transit and cover grip ribs (3b) to improve the patient grip to open the cover (3). The cover (3) also drives the device internal inhalation and metering mechanism. When the cover (3) is rotated open it reveals a mouthpiece (4) through which the patient is able to inhale the final active blend:

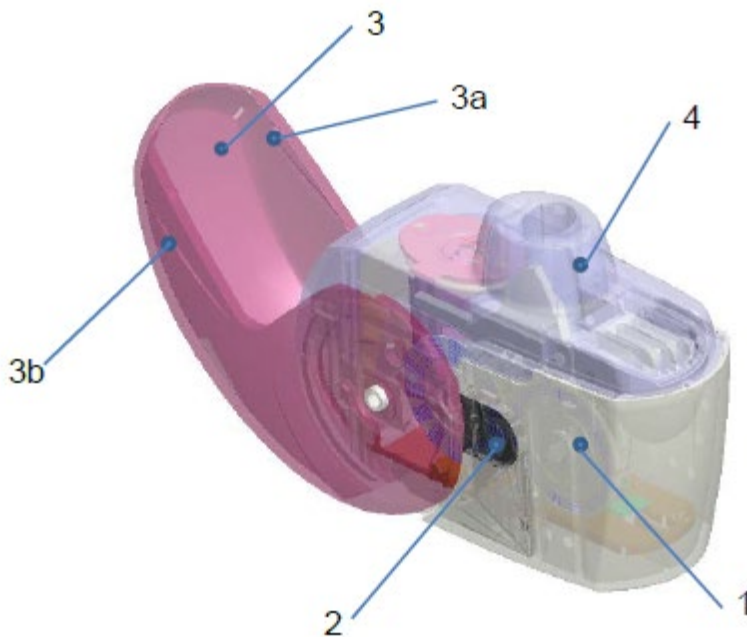

The device contains a dose counter that indicates the number of doses remaining and decrements the number, by one, each time a dose is taken (6) as shown below:

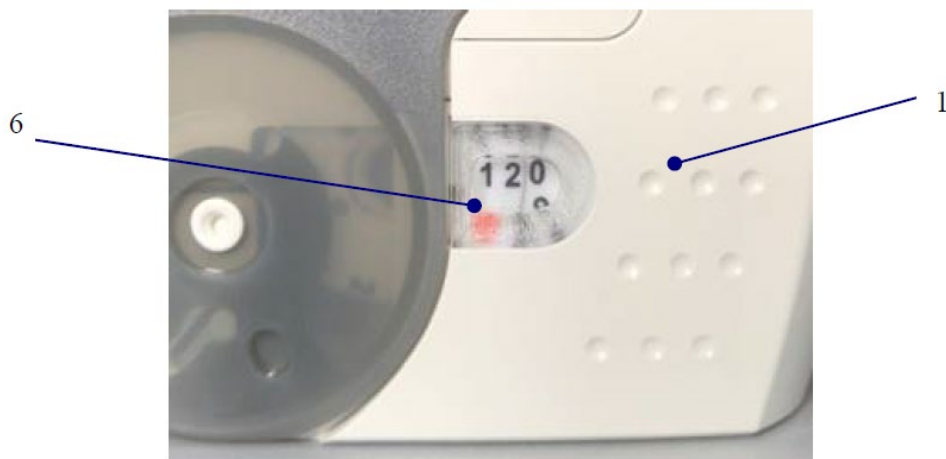

A threshold Peak Inspiratory Flow (PIF) is required to trigger the breath actuated mechanism (BAM) of the inhaler and if this threshold PIF cannot be achieved by the patient, inhaler use will be unsuccessfully. The peak inspiratory flow achieved by the patient is not only dependent on a patient's inhalation effort but also on the internal resistance of the inhaler.

Trydonis DPI is a multidose pre-loaded device containing 120 doses.

An overview of the Chiesi Trydonis and Foster portfolios were provided along with the authorised or proposed packaging elements and corresponding colours schemes. The use of different colours across the packaging elements and the inhalers will likely ensure the correct management and differentiation within the Trydonis and the Foster portfolios since the two product "families" significantly differ in terms of colour schemes.

The clinical development programme of CHF 5993 DPI was conducted according to the following CHMP guidelines:

- EMA/CHMP/158268/2017: Guideline on clinical development of fixed combination medicinal products;
- EMA/CHMP/483572/2012: Guideline on clinical investigations of medicinal products in the treatment of Chronic Obstructive Pulmonary Disease (COPD);
- CPMP/EWP/4151/00 Rev. 1: Requirements for clinical documentation for orally inhaled products (OIP) including the requirements for demonstration of therapeutic equivalence between two inhaled products for use in the treatment of Asthma and Chronic Obstructive Pulmonary Disease (COPD) in adults and for use in the treatment of asthma in children and adolescents.

The main rationale for the development of CHF 5993 DPI was to make the extra-fine single -inhaler triple therapy option (BDP/FF/GB) available for patients who prefer the use of a DPI, or who are unable to use a pMDI correctly.

The main objective of the clinical development programme for CHF 5993 DPI was to demonstrate equivalence between CHF 5993 DPI and the already authorised CHF 5993 pMDI for each of the individual components (BDP, FF and GB) by a direct comparison between these two products in accordance with the orally inhaled product (OIP) guideline (CPMP/EWP/4151/00 Rev. 1, 2009) and scientific advices received from CHMP (EMA/H/SA/3068/1/2015/III, EMA/CHMP/SAWP/432923/2017).

EMA/H/SA/3068/1/2015/III: The Company was seeking a SWP/CHMP advice on the quality, non-clinical and clinical development plan to support registration for the DPI formulation.

EMA/CHMP/SAWP/432923/2017: The Company was seeking a follow-up CHMP/SAWP advice on the design of the proposed PD study as well as on the overall clinical plan to support registration for the DPI formulation.

After an *in vitro* comparison between CHF 5993 DPI and CHF 5993 pMDI, a step-wise approach was followed to assess the potential impact of any differences on pharmacokinetics (PK) and on clinical efficacy and safety parameters.

<p>Step 1 – Quality (investigate in vitro performance)</p>	<p>Step 2 – PK PK study (investigate total systemic exposure and lung availability)</p>	<p>Step 3 – Clinical TRI-D study (demonstrate non-inferiority compared to CHF 5993 pMDI in terms of clinical efficacy and safety)</p>
---	--	--

In addition to the CHMP SAs, advices were received from the CHMP Rapporteur/PRAC-Rapporteur in a Pre-Submission Meeting held in November 2019.

2.4. Quality aspects

2.4.1. Introduction

The finished product subject of this line extension, Trydonis 100/6/12.5 (also referred to as CHF 5993 NEXThaler), is presented as an inhalation powder; since it is delivered through a dry powder inhaler (DPI), the finished product is also referred to as Trydonis 100/6/12.5 DPI. The inhalation powder is a fixed dose combination of beclometasone dipropionate, formoterol fumarate dihydrate and glycopyrronium bromide. It is a new dosage form of the already authorised Trydonis 87/5/9 pressurised inhalation solution (EMA/H/C/004257) which is delivered through a pressurised metered-dose inhaler (pMDI), hence, it is also referred to as 87/5/9 pMDI.

Each delivered dose (the dose leaving the mouthpiece) contains 88 micrograms of beclometasone dipropionate, 5 micrograms of formoterol fumarate dihydrate and 9 micrograms of glycopyrronium (as 11 micrograms glycopyrronium bromide).

Each metered dose contains 100 micrograms of beclometasone dipropionate, 6 micrograms of formoterol fumarate dihydrate and 10 micrograms of glycopyrronium (as 12.5 micrograms glycopyrronium bromide).

Other ingredients are: lactose monohydrate and magnesium stearate

As described in section 6.5 of the SmPC, the product is available in a white inhaler with a grey mouthpiece cover and a counter for the inhalations. It consists of a casework comprising of a lower shell with window to display number of inhalations left and an integral cover. When opened, the cover, which also drives the dose counter mechanism, reveals a mouthpiece through which the medicinal product is inhaled. The lower shell and mouthpiece are made from acrylonitrile butadiene styrene and the cover is made from polypropylene. The inhaler is packed into a thermo welded Polyamide/Aluminium/Polyethylene (PA/Al/PE) or Polyethylene-Terephthalate/Aluminium/ Polyethylene (PET/Al/PE) pouch.

2.4.2. Active substances

The active substances beclometasone dipropionate (BDP), formoterol fumarate dihydrate (FF) and glycopyrronium bromide (GB) used in the manufacture of Trydonis 100/6/12.5 DPI are also used in the manufacture of the authorised Trydonis 87/5/9 pMDI (EMA/H/C/004702), hence, limited data has been provided under 3.2.S; this is accepted.

All the active substances are supported by CEP. The micronisation of each active substance has been adequately accounted for. The physical characteristics of the active substances which may have an impact on the finished product aerodynamic performance have been discussed in the pharmaceutical development section below. The active substances' specifications have been updated to include particle size. The specification limits have been justified based on development data, including batches used in the bioequivalence study. The particle size distribution is determined by laser diffraction and the method has been described and validated for each active substance. Otherwise, the specifications are identical to those for the active substances used in the pMDI formulation.

The active substance specifications for the three active substances comply with the specifications and test methods of the European Pharmacopoeia, as applicable.

2.4.3. Finished medicinal product

Description of the product and Pharmaceutical development

The finished product subject of this line extension, Trydonis 100/6/12.5 micrograms (also referred to as CHF 5993 DPI), is presented as an inhalation powder. The qualitative and quantitative composition of the finished product is provided.

An over-fill has been introduced to ensure delivery of the nominal number of inhalations (120) stated on the label, throughout the shelf-life of the finished product. No overage is proposed.

The inhalation powder is a blend of the three active substances with lactose and magnesium stearate.

All excipients are well known pharmaceutical ingredients used for this route of administration, pharmaceutical form and their quality is compliant with Ph. Eur. standards. There are no novel excipients used in the finished product formulation. The list of excipients is included in section 6.1 of the SmPC and in paragraph 2.1.1 of this report.

The DPI has been developed to increase the therapeutic options for patients unable to use the marketed pMDI correctly, in view of the more complex inhalation technique required for to ensure that the dose is inhaled rather than deposited in the oral cavity. With pMDIs, the patient has to coordinate breathing actuating the inhaler; when using a DPI, the inhalation also triggers the actuation of the dose. The applicant has experience in the development and manufacture of DPI products; the main difference between their nationally authorised Foster 100/6 DPI and Trydonis 100/6/12.5 DPI is that Trydonis DPI also includes GP. Trydonis 100/6/12.5 DPI is identical to Trimbrow 100/6/12.5 DPI. The inhalation device is in common to the above-mentioned DPI products.

The pharmaceutical development of the finished product contains QbD elements. The quality target product profile (QTPP) was defined as a stable, free-flowing formulation with a high and reproducible aerodynamic performance resulting into the desired lung deposition when using the proposed device.

The formulation and manufacturing development have been evaluated through the use of risk assessment and design of experiments (DoE) to identify the critical product quality attributes and critical process parameters. Risk analysis was performed using the failure mode and effects analysis (FMEA) and/or the fault tree analysis (FTA) methods in order to identify the risk criteria that may have an influence on the finished product quality attributes. The risk identification was based on the prior knowledge of products with similar formulations and manufacturing processes as well as on the experience from formulation development, process design and scale-up studies. The critical process parameters have been adequately identified.

The composition of the active substances per metered dose in the DPI is the same as in the pMDI product. Early formulation development and process trials showed the effect of formulation and process changes on the aerosol performance is similar for the three active substances. Once the composition of the DPI formulation was identified to achieve the desired *in vitro* pharmaceutical performance (i.e. aerodynamic particle size distribution), several studies, including a full factorial DoE study were carried out to assess the potential effect of the three active substances' particle size distributions (PSD of FF, GB and BDP) on product performance. For all the active substances, the mean DD and FPM results are all within the development and proposed specifications, confirming the robustness of the formulation.

Therapeutic equivalence of the DPI product with the pMDI product cannot be demonstrated using *in vitro* results alone as the pharmaceutical form and the delivery devices differ. Therefore, a pharmacokinetic (PK) study was conducted examining two prototype DPI products with the same quantitative and qualitative formulation but with different aerodynamic performance due to differences in PSD. Neither DPI product showed bioequivalence to the pMDI product. The DPI product that showed

a closer performance to the pMDI product was evaluated in a pharmacodynamic (PD) study and was demonstrated to meet the criteria of bioequivalence as discussed in the clinical section. This approach is in line with the "Guideline on the requirements for clinical documentation for orally inhaled products (OIP) including the requirements for demonstration of the therapeutic equivalence between two inhaled products for use in the treatment of asthma and chronic obstructive pulmonary disease (COPD) in adults and for use in the treatment of asthma in children and adolescents" CPMP/EWP/4151/00 Rev.1 and had previously been endorsed in a Scientific Advice procedure. The FPM limits were set in line with the DPI product investigated during the PK and PD studies. The formulation used during clinical studies is the same as that intended for marketing.

The process development was performed focusing on the development of the micronisation process of GB and the development of the blending and filling manufacturing process. Whilst the blending investigation discusses a design space, no design space is claimed for blending or other steps of the manufacturing process. During the procedure, the applicant confirmed that only normal operating ranges are applicable for the manufacturing method. The studies confirmed the blending time ranges proposed for routine manufacture and the capability of the filling process. A process validation study, using different raw material batches, demonstrated good reproducibility and robustness within the variations investigated.

The primary packaging is a white inhaler with a grey mouthpiece cover and a counter for the inhalations, also referred to as NEXThaler and as NEXT DPI. The development of the device was performed for Foster. The NEXThaler has been modified with minor adaptations for Trydonis 100/6/12.5 DPI (e.g. change in component colour). The NEXThaler, depicted in Figure 1 below, is a reservoir medium resistance (45 L/min) device, hence suitable for a broad patient population, including children and the elderly. It consists of casework comprising a lower shell (1) with window to display dose counting numbers (2) and an integral cover (3), with cover retention clips (3a) to hold the cover (3) in the closed position during transit and cover grip ribs (3b) to improve the patient grip to open the cover (3). The cover (3) also drives the device internal inhalation and metering mechanism. When the cover (3) is rotated open it reveals a mouthpiece (4) through which the patient is able to inhale the final active blend.

Figure 1: The NEXThaler

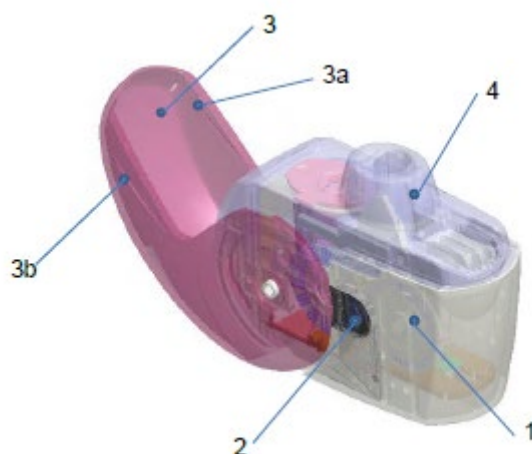

The lower shell and mouthpiece are made from acrylonitrile butadiene styrene and the cover is made from polypropylene. The inhaler is packed into a thermo welded Polyamide/Aluminium/Polyethylene (PA/Al/PE) or Polyethylene-Terephthalate/Aluminium/ Polyethylene (PET/Al/PE) pouch, a functional

secondary packaging material. The materials of the primary packaging comply with Ph. Eur. and EC requirements.

The choice of the container closure system has been validated by stability data and by meeting the requirements outlined in the "Guideline on the Pharmaceutical Quality of Inhalation and Nasal Products" (EMA/CHMP/QWP/49313/2005). The studies performed are summarised in Table 5 below are satisfactory, confirming that the device is adequate for the intended use of the product.

Table 1: finished product pharmaceutical development studies

CHMP/QWP/49313/2005 (reference paragraph)	Study name
4.2.1.2	Minimum fill justification
4.2.1.4	Delivered dose uniformity and fine particle mass through container life
4.2.1.4	Tailing
4.2.1.5	Delivered dose uniformity and fine particle mass over patient flow rate range
4.2.1.7	Single dose fine particle mass
4.2.1.8	Particle size distribution
4.2.1.9	Mouthpiece deposition
4.2.1.14	Cleaning requirements
4.2.1.17	Effect of environmental moisture
4.2.1.18	Robustness (Dropping, Vibration & Shock)

Manufacture of the product and process controls

The process is typical of those used to manufacture inhalation powders, which are considered specialised pharmaceutical forms and their manufacture is considered to be a non-standard process.

The manufacturing process as well as in-process controls performed have been sufficiently described. In-process controls have been identified and are considered adequate.

The holding times for the intermediate and for the final blend are supported by stability data and are acceptable.

It has been demonstrated that the manufacturing process is capable of producing the finished product of intended quality in a reproducible manner. The in-process controls are adequate for this pharmaceutical form.

Product specification

The finished product release specifications include appropriate tests for this kind of dosage form, namely: appearance/description of the inhaler and dry powder (visual), number of inhalations (Ph. Eur.), identification of the active substances (UPLC and UPLC/UV), assay of each active substance (UPLC), degradation products of each active substance (UPLC), FPM of each active substance (NGI/HPLC), mean DD and uniformity of DD for each active substance (Ph. Eur.-DUSA HPLC) and microbial count (Ph. Eur.).

The proposed finished product specification contains the required tests for this dosage form and it is in line with the Guideline on the Pharmaceutical Quality of Inhalation and Nasal Products.

The limits for impurities and degradation products at release and over the shelf life are in agreement with ICH Q3B. Adequate information on genotoxic impurities that could reasonably form in the finished product has been provided during the procedure.

The potential presence of elemental impurities in the finished product has been assessed following a risk-based approach in line with the ICH Q3D Guideline for Elemental Impurities. Batch analysis data using a validated ICP-MS method was provided, demonstrating that each relevant elemental impurity was not detected above 30% of the respective PDE. Based on the risk assessment and the presented batch data, it can be concluded that it is not necessary to include any elemental impurity controls. The information on the control of elemental impurities is satisfactory.

A risk evaluation was conducted concerning the presence of nitrosamine impurities in the finished product has been provided in line with the "Questions and answers for marketing authorisation holders/applicants on the CHMP Opinion for the Article 5(3) of Regulation (EC) No 726/2004 referral on nitrosamine impurities in human medicinal products" (EMA/409815/2020). It was confirmed that no risk of the presence of nitrosamine impurities in the active substance or the related finished product was identified. Therefore, no additional control measures are deemed necessary.

The analytical methods used have been adequately described and appropriately validated in accordance with the ICH guidelines. Satisfactory information regarding the reference standards used for assay and impurities testing has been presented.

Batch analysis results were provided confirming the consistency of the manufacturing process and its ability to manufacture to the intended product specification.

Stability of the product

Stability data from four production scale batches of finished product stored for up to 24 months under long term conditions (25 °C / 60% RH) and for up to 6 months under accelerated conditions (40 °C / 75% RH) according to the ICH guidelines were provided. The in-use stability studies were conducted over a period of 3 months, on the same batches used for the long study, to assess the product performance, after being dispensed to the patients outside the thermo-welded pouch and kept under long term conditions (25 °C / 60% RH). The batches of the finished product are identical to those proposed for marketing and were packed in the primary packaging proposed for marketing.

Samples were tested according to the shelf-life specifications. The analytical procedures used are stability indicating. No significant changes were observed in the long term and accelerated studies and all results were within the proposed specification limits. In the in-use study, several out-of-specification results were found from the 8-week data point onward. Therefore, the in-use shelf life of 6 weeks is considered justified. Since development studies at extreme humidity conditions indicate that high humidity can have an impact on the performance of the product, the un-pouched inhaler should be stored in a dry place.

No photostability stability studies were performed due to the nature of the container closure system. Since the DPI excludes light, this is accepted.

The following shelf life and storage precaution was proposed and can be granted based on the data available:

A shelf-life of 21 months below 25 °C for the pouched inhalers including a maximum of 6 weeks below 25 °C when stored in a dry place for the un-pouched inhalers, as stated in the SmPC (section 6.3) are acceptable.

Adventitious agents

It is confirmed that the lactose is produced from milk from healthy animals in the same condition as those used to collect milk for human consumption and that the lactose has been prepared without the use of ruminant material other than calf rennet according to the Note for Guidance on Minimising the Risk of Transmitting Animal Spongiform Encephalopathy Agents Via Human and veterinary medicinal products.

2.4.4. Discussion on chemical, and pharmaceutical aspects

With the current line extension, an additional dosage form (i.e. inhalation powder) is proposed for Trydonis. The information provided for Trydonis 100/6/12.5 DPI is of good quality. All three active substances have been approved in the initial application for Trydonis 100/6/12.5 pMDI and are micronised for the current DPI formulation to ensure bioequivalence. Information on the development, manufacture and control of the finished product has been presented in a satisfactory manner. The results of tests carried out indicate consistency and uniformity of important product quality characteristics, and these in turn lead to the conclusion that the product should have a satisfactory and uniform performance in clinical use.

2.4.5. Conclusions on the chemical, pharmaceutical and biological aspects

The quality of this product is considered to be acceptable when used in accordance with the conditions defined in the SmPC. Physicochemical and biological aspects relevant to the uniform clinical performance of the product have been investigated and are controlled in a satisfactory way.

2.5. Non-clinical aspects

2.5.1. Introduction

CHF 5993 DPI is a triple fixed dose combination of the inhaled corticosteroid (ICS) beclometasone dipropionate (BDP), the long-acting β_2 -agonist (LABA) formoterol fumarate (FF) and the long-acting muscarinic antagonist (LAMA) glycopyrronium bromide (GB).

The non-clinical development of CHF 5993 DPI was based on the following assumptions:

- 1) BDP and FF are well known representatives of the ICS and LABA classes and have been used in established therapies for many years, both as single components and in a fixed dose combination (FDC);
- 2) The non-clinical package of the FDC of BDP and FF has been evaluated positively in the approval of the Chiesi product, Foster and associated brand names (as both pMDI and DPI);
- 3) GB is a well-known representative of the LAMA class which is approved for use via oral administration as well as intravenous or intramuscular injection in several countries at a dose resulting in higher systemic exposure than for an inhaled dosage form.

Additionally, GB was approved as an inhalation maintenance bronchodilator treatment for COPD in the EU (Seebri Breezhaler) and Japan in September 2012 and is now approved in more than 50 countries.

- 4) The non-clinical package of CHF 5993 pMDI has been evaluated in the approval of CHF 5993 pMDI.

In accordance, for the non-clinical data on Pharmacology, Pharmacokinetics and Toxicology, the applicant referred to the studies submitted for the CHF 5993 pMDI MAA dossier. A summary of the results of these studies was provided as part of this application.

To provide assurance for the safety of the new CHF 5993 DPI dosage form following the change from a pMDI-delivered solution to a DPI-delivered powder, the applicant performed additional repeat dose inhalation bridging toxicity studies (including an evaluation of toxicokinetics and of local tolerance in the respiratory system) of 4- and 13-week duration in rats and dogs for the CHF 5993 DPI dosage form. A summary of the results of these new studies was provided as part of this application.

The CHF 5993 DPI formulation contains lactose monohydrate and magnesium stearate, ingredients commonly and safely used in other pharmaceutical products for inhalation. For this reason and since toxicological data on these excipients are available, separate preclinical studies on these compounds were not conducted, nor are required. However, in the repeat dose inhalation toxicity studies the animals of the control groups were exposed to the vehicle only (lactose and magnesium stearate powder blend).

2.5.2. Pharmacology

Concerning Primary Pharmacodynamics, Secondary Pharmacodynamics, Safety Pharmacology, and Pharmacological Drug Interactions the applicant has not presented new studies for CHF 5993 DPI but refers to the respective data that were submitted for the CHF 5993 pMDI MAA dossier.

2.5.3. Pharmacokinetics

Concerning Absorption, Distribution, Metabolism, Excretion and Pharmacokinetic Drug Interactions the applicant refers to the respective data that were submitted for the CHF 5993 pMDI MAA dossier.

In addition, specific toxicokinetic data have been obtained for the inhalation powder dosage form in the context of the new repeat dose bridging toxicity studies that were conducted for CHF 5993 DPI in rats and dogs.

2.5.4. Toxicology

Concerning Single Dose Toxicity, Genotoxicity, Carcinogenicity, Reproductive and Developmental Toxicity and Other Toxicity Studies the applicant refers to the respective data that were submitted for the CHF 5993 pMDI MAA dossier.

Repeat dose toxicity studies (including Local tolerance)

In this application, the Applicant provided new data in rats and dogs in 4 and 13-week repeat dose inhalation toxicities studies to investigate systemic effects and the local tolerability on the respiratory system of CHF 5993 DPI. No longer studies were carried out since no unexpected findings and no exacerbation of toxicity were found. Overall, the main effects seen were attributable to the known pharmacological effects of corticosteroids, β 2-agonists and M3 antagonists.

On the basis of the included toxicokinetic evaluations, safety margins with respect to the clinical dosage have been calculated by the applicant on the basis of the human and animal exposure (C_{max}

and AUC) and considering 400+24+50 µg/day of BDP+FF+GB as maximum daily clinical inhalation dose.

Rat studies

4-week CHF 5993 DPI free combination inhalation toxicity in rats with 4 weeks recovery

In a 4-week inhalation study, male and female Wistar rats were exposed by nose-only inhalation, 1 hour/day for 28 consecutive days to CHF 5993 DPI generated from the combination of Foster DPI (100+6 µg BDP+FF in 10 mg blend) and GB DPI (25 µg in 10 mg blend) and delivered at achieved inhaled doses of 115+5.5+32, 258+14+87 and 1053+50+321 µg/kg/day BDP+FF+GB. Two additional groups were treated with the single components at the corresponding high doses of Foster (BDF+FF) DPI 1045+52 µg/kg/day and GB DPI 268 µg/kg/day. The rats of the control group were exposed to only (lactose and magnesium stearate powder blend), at exposure conditions similar to the ones used to generate the high dose combination. A period of 4 weeks of recovery followed the end of dosing. The Mass Median Aerodynamic Diameter (MMAD) of the active compounds ranged between 1.44 and 3.27 µm, showing adequate respirability for the rat.

Overall, the results were in line with those obtained in the 13-week repeat dose toxicity study in rats described below.

13-week CHF 5993 DPI fixed combination inhalation toxicity in rats with 6 weeks recovery

In a 13-week inhalation study, male and female rats were exposed by nose-only inhalation, 1 hour/day over 13 weeks to CHF 5993 DPI (100+6+12.5 µg BDP+FF+GB in 10 mg blend) at achieved doses of 105+5.9+12, 325+18+36 and 920+51+100 µg/kg/day respectively of BDP+FF+GB. Two additional groups were treated with the single components at the following doses: Foster (BDF+FF) DPI 965+54 µg/kg/day and GB DPI 113 µg/kg/day. The animals of the control group were exposed to lactose and magnesium stearate powder blend only, at conditions similar to the high dose combination.

The aerosols generated were well within the respirable range of the rat with MMADs ranging between 1.8 and 3.3 µm for all the active ingredients.

Main study findings:

These doses were well tolerated but BDP-associated effects (increased body weight gain, slight red blood cells, haematocrit and haemoglobin increase and white blood cells (lymphocytes) or platelets decreased, metabolism-affected plasma levels with slight changes in urea, creatinine, potassium and triglycerides, increased urinary volume, minimal to moderate atrophy of the thymus and minimal to slight adrenal cortex hypertrophy) were observed respectively at high dose or according to a dose-relationship at all dose levels.

Toxicokinetics

All animals in the treated groups were exposed systemically to BDP, formoterol and/or glycopyrronium and their metabolites.

- Systemic exposures of all analytes increased with increasing doses although a clear proportionality was not observed for any analyte.
- Exposure to B17MP was higher than that of its parent BDP, while cyclopentylmandelic acid (CMA) exposure was lower than that of its parent compound glycopyrronium.
- No notable accumulation of any of the compounds was observed.

Conclusions

BDP-associated effects [e.g. increased body weight gain; red blood cells, haematocrit and haemoglobin increase; decrease in white blood cells (lymphocytes) and platelets; increased urinary volume, minimal to moderate atrophy of the thymus and minimal to slight adrenal cortex hypertrophy] were observed. The incidence and magnitude of the changes was generally not different for the high-dose BDF+FF+GB combination (CHF 5993) when compared with BDF+FF administered alone.

All the changes fully recovered after 4 weeks of recovery.

The Applicant considered none of the treatment-related effects as adverse and therefore defines the high-dose of 920+51+100 µg/kg/day BDP+FF+GB as the NOAEL.

Since BDF-related effects were observed at all BDF+FF+GB doses, the low-dose (105+5.9+12 µg/kg/day) was defined as LOEL.

Safety margin calculations

During clinical development it was demonstrated that the systemic exposure of humans for the CHF 5993 DPI dosage form was comparable to that of the CHF 5993 pMDI dosage form (PK study). For this reason, human systemic exposure data from the CHF 5993 pMDI clinical trial (CARSAF study, pMDI application) were used by the Applicant to calculate the safety margins versus systemic exposures in animals at the NOAEL defined by the Applicant.

On basis of the systemic exposure (AUC) at the NOAEL defined by the Applicant for rats, the Applicant calculated safety margins (exposure multiples) of at least 67 for B17MP, 26 for FF and 30 for GB.

Plasma concentrations of BDP were only quantifiable for 1 or 2 hours after the start of inhalation, and, due to the paucity of data, the AUC₀₋₂₄ for BDF was not determined. However, safety margins based on measured C_{max} at the Applicant defined NOAEL could be calculated (Tables 8 and 9).

Table 2: Systemic safety margin calculation on basis of AUC at NOAEL

	Rat 13 week AUC ₀₋₂₄ at NOAEL		COPD Patients AUC ₀₋₂₄ [§]	Safety margins	
	ng.hr/mL		ng.hr/mL	-	
	Male	Female		Male	Female
BDP	n.d.	n.d.	0.139	-	-
B17MP	310	1540	4.65	67	331
FF	4.15	4.59	0.161	26	28
GB	9.55	11.6	0.320	30	36

[§]AUC₀₋₂₄ extrapolated from the AUC₀₋₁₂ at steady state in the CARSAF study with CHF 5993 pMDI given 400/24/50 mg day (b.i.d.) for 14 days.

Table 3: Systemic safety margin calculation on basis of C_{max} at NOAEL

	Rat 13 week C _{max} at NOAEL		COPD Patients C _{max} [§]	Safety margins	
	ng/mL		ng/mL	-	
	Male	Female		Male	Female
BDP	19.4	21.5	0.367	53	58
B17MP	71.6	219	0.678	105	323
FF	1.90	2.38	0.017	112	140
GB	2.81	2.97	0.046	61	64

[§]C_{max} extrapolated from the the CARSAF study with CHF 5993 pMDI given 400/24/50 mg day (b.i.d.) for 14 days.

Dog studies

4-week CHF 5993 DPI free combination inhalation toxicity in dogs with 4 weeks recovery

In a 4-week inhalation study, male and female Beagle dogs were exposed by nose-only inhalation, 30 min/day for 28 consecutive days to CHF 5993 DPI generated from the combination of Foster DPI (100+6 µg BDP+FF in 10 mg blend) and GB DPI (25µg in 10mg blend) and delivered at achieved inhaled doses of 38+2+12, 154+8+50 and 465+26+162 µg/kg/day BDP+FF+GB. Two additional groups were treated with the single agents at the following doses Foster (BDF+FF) DPI 657+34 µg/kg/day and GB DPI 164 µg/kg/day. The animals of the control group were exposed to lactose and magnesium stearate powder blend only, at conditions similar to the high dose combination. A recovery period of 4 weeks followed the end of treatment.

To prevent acute tachycardia associated with the pharmacological effects of formoterol, escalation doses were introduced prior to starting the constant 4-week dose phase for animals of mid and high-dose groups of the BDF+FF+GB combination or Foster DPI alone.

The MMADs of the active compounds ranged between 1.31 and 3.45 µm, showing adequate respirability for the dog.

Overall, the results were in line with those obtained in the 13-week repeat dose toxicity study in dogs presented below.

13-week CHF 5993 DPI fixed combination inhalation toxicity in dogs with 6 weeks recovery

The fixed-dose combination of CHF 5993 DPI (100+6+12.5 µg BDP+FF+GB in 10 mg blend) was given by inhalation to dogs for 1 hour/day over 13 weeks at achieved inhaled doses of 35.4+1.94+3.93, 133+7.26+14.4 and 596+33.1+62.4 µg/kg/day from Week/Day 1/1 to 6/6 and 279+15.7+29.5 µg/kg/day as high-dose from Week/Day 6/7 to 13/7 (423+23.6+44.5 µg/kg/d overall dose calculated as a time weighted average of doses) respectively of BDP+FF+GB.

The animals of the control group were exposed to only lactose and magnesium stearate powder blend, at conditions similar to the high dose combination.

Two additional groups were treated with the single components at the following doses: Foster (BDP+FF) DPI 373+19.9 µg/kg/day and GB DPI 45.4 µg/kg/day.

Escalation dose phases were introduced for groups given the medium or high dose of formoterol to reduce the risk of ventricular tachycardia associated with the initial cardiac pharmacological effects of beta2-agonists.

The aerosols generated were within the respirable range for the dog with MMADs ranging between 1.4 and 2.8 µm for all the active compounds.

Main study findings

Mortality / Dose adjustment

At the start of treatment animals in the high dose BDP+FF+GB group were given 596+33.1+62.4 µg/kg/day for the first 6 weeks of the study but due to severe side effects in one animal (detailed below) it was decided to halve the doses to prevent further occurrences of death. Accordingly, between Week 7 and Week 13, the animals in the high dose BDP group were given 279+15.7+29.5 µg/kg/day of CHF 5993 inhalation powder.

The decedent was a female sacrificed in Week 6 due to severe clinical signs. The major factor contributory to death was considered to be the lung lesions (inflammation, necrosis, oedema and haemorrhage), most likely due to immunosuppression. The Applicant considered that based on the extensive clinical practice with inhaled BPD, these effects seen in dogs have no relevance in humans.

No further deaths were observed after reduction of the high dose.

Other treatment-related clinical signs observed after administration of the highest dose were limited to reddening of gums, ears and/or ventral surface (with a reduced frequency after Week 6). Electrocardiography showed heart rate increase, persisting to 4 hours post dose, during the escalation dose phase, Weeks 1, 6 and 13 for animals treated with CHF 5993 DPI.

Heart rates were increased in a dose-dependent manner and generally declined over the study period. Slight decreases in PR interval and increases in QTcR were observed consistently with the heart rate changes. These heart rates correlated with the clinical observation of skin reddening. Group mean triglyceride, total protein and albumin values were higher than control for one or both sexes given CHF 5993 DPI. Histopathological examination revealed BDP-related findings at all dose levels in the adrenals (atrophy and hypertrophy), liver (increased glycogen), gall bladder (epithelial vacuolation), thymus (atrophy), decreased cellularity in the lymph nodes (mesenteric, mandibular, tracheobronchial and axillary) and Peyer's Patches and squamous cell papilloma in the oral cavity, which all support the immunosuppressed status of CHF 5993-treated dogs (especially at mid and high doses).

Conclusions

- Electrocardiography showed heart rate increase, persisting to 4 hours post dose, during the escalation dose phase and weeks 1, 6 and 13 for animals treated with CHF 5993 DPI.
- Heart rates were increased in a dose-dependent manner and generally declined over the study period. Slight decreases in PR interval and increases in QTcR were observed, consistently with the heart rate changes. The increase in heart rates correlated with the clinical observation of skin reddening.
- Group mean triglyceride, total protein and albumin values were higher than control for one or both sexes given CHF 5993 DPI.
- Histopathological examination revealed BDP-related findings at all dose levels in the adrenals (atrophy and hypertrophy), liver (increased glycogen), gall bladder (epithelial vacuolation), thymus (atrophy), decreased cellularity in the lymph nodes (mesenteric, mandibular, tracheobronchial and axillary) and Peyer's Patches and squamous cell papilloma in the oral cavity, which all reflect the immunosuppressed status of CHF 5993 DPI-treated dogs (especially at mid and high doses).

Recovery from these findings was observed after 6 weeks off dose.

Overall, the effects of the fixed-dose combination CHF 5993 DPI were no relevantly different in incidence or severity from those seen with Foster (BDF+FF) given alone and were not exacerbated by the presence of GB.

Safety margin calculations

Due to the decedent at the high dose of 596+33+62 µg/kg/day BDP+FF+GB, the Applicant considered this dose level as adverse. Although no further mortality was observed after reducing the high dose to 279+15.7+29.5 µg/kg/day, the Applicant considered the NOAEL to be the mid BDP+FF+GB-dose (133+7.26+14.4 µg/kg/day).

As for the rat data (presented above), human systemic exposure data from the CHF 5993 pMDI clinical trial (CARSAF study, CHF 5993 pMDI application) were used to calculate the safety margins versus the systemic exposures of dogs at the NOAEL defined by the Applicant for the CHF 5993 inhalation powder formulation.

For AUC, safety margins (exposure multiples) of at least 3 for B17MP, 4.2 for FF and 5.1 for GB were determined at the NOAEL defined by the Applicant (Table 10). Plasma concentrations of BDP were only quantifiable at 1 or 2 hours after the start of inhalation and due to the paucity of data, the AUC₀₋₂₄ for BDP was not determined.

For Cmax, the corresponding safety margins are reported below in Table 11.

Table 4: Safety margin calculation on basis of AUC at NOAEL

	Dog 13 week AUC ₀₋₂₄ at NOAEL		COPD Patients AUC ₀₋₂₄ ⁵	Safety margins	
	ng.hr/mL		ng.hr/mL	-	
	Male	Female		Male	Female
BDP	nd	nd	0.139	-	-
B17MP	13.9	14.7	4.65	3	3.2
FF	0.878	0.684	0.161	5.4	4.2
GB	2.65	1.63	0.320	8.3	5.1

⁵AUC₀₋₂₄ extrapolated from the AUC₀₋₁₂ at steady state in the CARSAF study with CHF 5993 pMDI given 400/24/50 mg day (b.i.d.) for 14 days.

Table 5: Safety margin calculation on basis of Cmax at NOAEL

	Rat 13 week Cmax at NOAEL		COPD Patients Cmax [#]	Safety margins	
	ng/mL		ng/mL	-	
	Male	Female		Male	Female
BDP	1.59	1.91	0.367	4.3	5.2
B17MP	5.87	6.80	0.678	8.6	10
FF	0.275	0.221	0.017	16.2	13
GB	0.367	0.345	0.046	8.0	7.5

[#]Cmax extrapolated from the CARSAF study with CHF 5993 pMDI given 400/24/50 mg day (b.i.d.) for 14 days.

Local tolerance

No separate studies were conducted with CHF 5993 DPI; however, its local tolerance was tested during the 4- and 13-week inhalation repeat dose toxicity studies in rats and dogs performed with the inhalation powder formulation (presented above).

The lung doses corrected for lung deposition and for the alveolar surface area (see Table 12) were calculated. Data for the highest inhaled doses of CHF 5993 DPI tested in the 13-week toxicity studies in rat and dog, respectively, are presented in

Table 13 and 14.

Table 6: Lung surface area comparison between species

	BODYWEIGHT (KG)	ALVEOLAR SURFACE AREA (M²)	SOURCE
RAT	0.250	0.34	U.S. EPA 1994
DOG	10-15	40.7	Appendix F OEHHA (Office of Environmental Health Hazard Assessment), June 2008
HUMAN	60	54	Fernandes et al, 2009

Table 7: Safety margin calculation for lung dose for the rat 13-week toxicity study

TEST ITEMS	RAT – 13 WEEK TOX STUDY		HUMAN DAILY DOSE		SAFETY MARGIN
	NOAEL for local toxicity (µg/kg/day)	Corresponding Lung dose (µg/m ² alveolar surface) §	µg/day #	Corresponding Lung dose (µg/m ² alveolar surface) §	
BDP	920	68	400	7.4	9
FF	51	3.7	24	0.4	9
GB	100	7.3	50	0.9	8

§ Includes a lung deposition factor of 10% of the inhaled dose in rat and 100% in human.

Proposed human dose: 400/24/50 µg/day of BDP/FF/GB

Table 8: Safety margin calculation for lung dose for the dog 13-week toxicity study

TEST ITEMS	DOG – 13 WEEK TOX STUDY		HUMAN DAILY DOSE		SAFETY MARGIN
	NOAEL for local toxicity (µg/kg/day)	Corresponding Lung dose (µg/m ² alveolar surface) §	µg/kg/day #	Corresponding Lung dose (µg/m ² alveolar surface) §	
BDP	423	26	400	7.4	6.5
FF	23.6	1.4	24	0.4	3.5
GB	44.5	3	50	0.9	3.3

§ Includes a lung deposition factor of 25% of the inhaled dose in dog and 100% in human.

Proposed human dose: 400/24/50 µg/day of BDP/FF/GB

2.5.5. Ecotoxicity/environmental risk assessment

An updated ERA (included below) for the active substances beclometasone dipropionate (pro-drug), formoterol fumarate dihydrate and glycopyrronium bromide had been provided based on the ERA which had been considered complete and acceptable. A risk to the environment was not indicated. No new experimental studies were provided for the present extension application.

At time of initial authorisation, all PEC_{sw} values were clearly below the Phase I action limit of 0.01 µg/l. Therefore, for formoterol fumarate dihydrate (FF) and glycopyrronium bromide (GB) an assessment in Phase II Tier A was not required. However, due to the potential endocrine disrupting properties of glucocorticoids, a tailored ERA for the active metabolite of beclometasone dipropionate (pro-drug), i.e. beclometasone-17-monopropionate (B17MP), had been performed. On the basis of the tailored ERA it was concluded that beclometasone is not readily biodegradable, not toxic to fish and not expected to bioconcentrate in fish. However, the parent compound is considered persistent in water/sediment systems as the relevant transformation products 'Met-L' and 'Epoxide of beclometasone' are considered very persistent and persistent in water, respectively. Beclometasone-17-monopropionate, formoterol fumarate and glycopyrronium bromide are not potential PBT substances.

The present extension to add a new pharmaceutical form is not expected to increase the environmental exposure as the maximum daily dose remains the same. Thus, the previous conclusions on the environmental risk are still valid. It can be expected that the present extension will not pose a risk to the environment when used in accordance with the SmPC.

Summary of main study results			
Phase I			
<i>PBT screening</i>			
	<i>Compound</i>	<i>Results</i>	<i>Conclusion</i>
<i>Bioaccumulation potential - log_{K_{ow}}</i>	BDP	4.1/3.49	Potential PBT (Y)
<i>Bioaccumulation potential - log_{K_{ow}}</i>	B17MP	3.49/3.14	Potential PBT (Y)
<i>Bioaccumulation potential - log_{K_{ow}}</i>	FF	-0.02/2.5	Potential PBT (N)
<i>Bioaccumulation potential - log_{K_{ow}}</i>	GB	-1.35/1.27	Potential PBT (N)
<i>PEC surfacewater (µg/L)</i>			
	BDP	0.002	Lower than 0.01 threshold
	FF	0.00012	Lower than 0.01 threshold
	GB	0.00025	Lower than 0.01 threshold
Phase II Physical-chemical properties and fate for B17MP			
<i>Study Type</i>	<i>Test protocol</i>	<i>Results</i>	<i>Conclusion</i>
<i>Ready Biodegradability test</i>	OECD301B	Not readily biodegradable	Additional evaluation required
<i>Aerobic and Anaerobic transformation in Aquatic Sediment system (DT₅₀ normalised to 12°C)</i>	OECD308	Emperor Lake Water: DT ₅₀ 3.0 days Overall system: DT ₅₀ 3.9 days	Lower dissipation
		Calwich Abbey Lake Aerobic: DT ₅₀ <1 day Anaerobic: DT ₅₀ <1 day	Rapidly dissipated
Phase II effect study for B17MP			
<i>Flow-through life-cycle toxicity test with the fathead minnow (Pimephales Promelas)</i>	OECD on Fish Life-Cycle Tests	NOEC 0.13 µg/L	B17MP is unlikely to represent a risk
<i>Bioaccumulation in Fish</i>	OECD305	No bioconcentration factor calculated	No accumulation occurred

2.5.6. Discussion on non-clinical aspects

Pharmacology

No new non-clinical studies concerning Primary Pharmacodynamics, Secondary Pharmacodynamics, Safety Pharmacology and Pharmacodynamics Drug Interactions of CHF 5993 DPI have been submitted for this line extension. Instead, the Applicant referred to respective data submitted during the initial MAA for CHF 5993 pMDI.

This is considered acceptable by the CHMP since the glucocorticosteroid activity (BDP), long-acting β 2-agonistic activity (FF) and M3 antagonistic activity (GB) of the active ingredients of CHF 5993 DPI, when applied as single agents or in combination, have been well-characterized in the non-clinical and clinical studies submitted previously.

Pharmacokinetics

Concerning absorption, distribution, metabolism and excretion, the applicant referred to the studies reports submitted during the initial MAA for CHF 5993 pMDI. This is considered acceptable since the basic ADME characteristics of the active ingredients BDP, FF and GB, when applied as single agents or in combination, have been well characterized in the non-clinical and clinical studies submitted previously. Furthermore, for characterization of the new DPI dosage form, additional toxicokinetic data have been provided by the applicant for CHF 5993 DPI in the context of the 4- and 13-week repeat dose inhalation bridging toxicity studies performed in rats and dogs for the current line extension application.

Overall, the approach followed by the applicant for characterization of PK is considered acceptable.

Toxicology

Single Dose Toxicity, Genotoxicity, Carcinogenicity, Reproductive and Developmental Toxicity and Other Toxicity Studies

No new non-clinical studies concerning these toxicological parameters have been provided. The applicant referred to the respective data that were submitted during the initial MAA for CHF 5993 pMDI. This is considered acceptable since these toxicological characteristics of the active ingredients BDP, FF and GB, when applied as single agents or in combination, have been adequately characterized in the non-clinical and clinical studies submitted previously.

In this respect, the currently approved SmPC for the CHF 5993 pMDI dosage form contains the following information.

Reproductive and development toxicity

Beclometasone dipropionate/beclometasone-17-monopropionate was considered responsible for reproductive toxicity effects in rats such as reduction of the conception rate, fertility index, early embryonic development parameters (implantation loss), delay in ossification and increased incidence of visceral variations; while tocolytic and anti-muscarinic effects, attributed to the beta2-adrenergic activity of formoterol and the anti-muscarinic activity of glycopyrronium, affected pregnant rats in the late phase of gestation and/or early phase of lactation, leading to loss of pups.

Genotoxicity

Genotoxicity of Trydonis has not been evaluated, however, the single active components were devoid of genotoxic activity in the conventional test systems.

Carcinogenicity

Carcinogenicity studies have not been performed with Trydonis. However, in a 104-week rat inhalation carcinogenicity study and an oral 26-week carcinogenicity study in transgenic Tg.rasH2 mice, glycopyrronium bromide showed no carcinogenic potential and published data concerning long-term studies conducted with beclometasone dipropionate and formoterol fumarate in rats do not indicate a clinically relevant carcinogenic potential.

Repeat dose toxicity studies

To provide reassurance concerning the safety of the new DPI dosage form of CHF 5993, the systemic effects and the local tolerability on the respiratory system of CHF 5993 inhaled powder was investigated in rats and dogs in repeat dose inhalation bridging toxicity studies of up to 13 weeks duration including recovery periods.

The effects seen in these studies appeared to be largely attributable to the known pharmacotoxicological effects of corticosteroids, β 2-agonists and M3-antagonists. The main observed alterations were related to effects on the immune system (probably due to systemic corticosteroid effects of BDP and its active metabolite B17MP) and on the cardiovascular system (probably related to the beta2-adrenergic activity of formoterol and the anti-muscarinic activity of glycopyrronium, most prominent in the dog studies). The toxicological profile of the triple combination was in line with the toxicological profile of the single active components without a relevant increase in toxicity and without unexpected findings. Since no unexpected findings and no exacerbation of toxicity were found, studies of duration > 13 weeks were not carried out.

Concerning study interpretation, the applicant is of the opinion that the observed effects should not be considered as adverse, since they appear to reflect exaggerated pharmacological effects and were (mostly) reversible in the recovery period. On this basis, the applicant defined the high-dose of CHF 5993 DPI in the 13-week rat study and the mid-dose in the 13-week dog study (since mortality occurred in the high dose) as the respective NOAEL values and provided AUC and Cmax-based safety margin calculations by comparison with the respective clinical exposure at the maximal recommended human COPD dose (400+24+50 μ g/day of BDP+FF+GB).

Nevertheless, the opinion of the Applicant that the observed systemic effects of CHF 5993 DPI on the immune and cardiovascular system should not be considered as adverse was not supported by CHMP. One of the main goals of inhalation therapy in COPD is to provide the desired local effects in the respiratory tract, but to avoid untoward systemic effects of the applied active substances. In the clinical setting, systemic effects during inhalation therapy on the immune system and/or cardiovascular system may have adverse consequences for the patient.

Furthermore, in the new repeat dose inhalation bridging toxicity studies in rats and dogs submitted for the current line extension application, systemic effects on the immune and/or cardiovascular system were already observed for the lowest tested CHF 5993 DPI doses, indicating that a NOAEL was not established in these studies.

Upon request by CHMP, the Applicant provided a detailed comparison of the new repeat dose inhalation toxicity studies for the DPI formulation with those previously submitted for the pMDI formulation, which revealed that, by and large, the systemic exposure to the active substances BDP/B17MP, FF and GB had been comparable for both formulations and provided reassurance that application of the CHF 5993 DPI formulation is not associated with any new, unexpected relevant systemic toxicity.

Local tolerance

No separate studies were conducted; however, the local tolerance of the inhalation powder formulation was evaluated during the new 4- and 13-week repeat dose inhalation toxicity studies in rats and dogs.

Taking into account lung surface area comparisons, the Applicant has calculated safety margins (exposure margins) for the clinical application of the CHF 5993 inhalation powder.

For the 13-week rat study, exposure multiples at the NOAEL for local tolerance (high-dose CHF 5993 DPI) of about 8 to 9 for the active substances were estimated, whereas for the 13-week dog study at the NOAEL for local tolerance (mid-dose CHF 5993 DPI), exposure multiples were in the range of 1. However, taking into consideration the lack of significant local tolerance-related findings at the mid CHF 5993 DPI dose and the known toxicology of and available clinical/epidemiological experience with the active substances in question, the CHMP considered this latter finding did not give rise to any relevant concern.

2.5.7. Conclusion on the non-clinical aspects

Overall, the non-clinical data submitted as part of this application are comparable to the non-clinical data submitted for the pMDI device. Therefore, the non-clinical data provided for the new device CHF 5993 DPI are considered appropriate.

2.6. Clinical aspects

2.6.1. Introduction

GCP aspects

The Clinical trials were performed in accordance with GCP as claimed by the MAH.

The MAH has provided a statement to the effect that clinical trials conducted outside the community were carried out in accordance with the ethical standards of Directive 2001/20/EC.

- **Tabular overview of clinical studies**

The clinical development programme included two studies:

- One PK, single supra-therapeutic dose study in healthy adults (hereafter also referred to as PK study; CCD-05993BA1-01);
- One Phase II, repeat therapeutic dose study in adult patients with moderate to severe COPD (hereafter also referred to as TRI-D study; CLI-05993BA1-02).

A post-authorisation safety study (PASS) is also planned and discussed in other sections below. An outline for this PASS is provided in the Risk Management Plan submitted as part of this application.

Results of the PK study, the design of the TRI-D study and the need for a PASS to support the approval of this LE application were discussed with CHMP/SAWP in 2017 (EMEA/H/SA/3068/1/2015/III, EMA/CHMP/SAWP/432923/2017).

Table 9: Overview of the clinical development

	PK study CCD-05993BA1-01	TRI-D study CLI-05993BA1-02
Study type	PK	Efficacy and safety
Design	Phase I, randomised, open-label, single-dose, two parallel cohort, partially replicated, 5-way cross-over study	Phase II, randomised, double-blind, double-dummy, active-controlled, 3-way cross-over study
Primary objectives	<p>To evaluate the total systemic exposure of B17MP (active metabolite of BDP), formoterol and GB, as AUC_{0-t} and C_{max}, after administration of two different formulations of CHF 5993 DPI, in comparison with CHF 5993 pMDI (with/without VHC)</p> <p>To evaluate the lung availability of B17MP, formoterol and GB, assessed as systemic exposure (AUC_{0-t} and C_{max}) upon gastrointestinal CB, after administration of two different formulations of CHF 5993 DPI, in comparison with CHF 5993 pMDI (with/without VHC)</p>	<p>To demonstrate the non-inferiority between CHF 5993 DPI and CHF 5993 pMDI in terms of FEV₁ AUC_{0-12h} normalised by time on Day 28</p> <p>To demonstrate the non-inferiority between CHF 5993 DPI and CHF 5993 pMDI in terms of trough FEV₁ at 24 hours on Day 28</p>
Study treatments and total dose	<p>CHF 5993 DPI with or without CB (formulation 1); CHF 5993 DPI with or without CB (formulation 2)</p> <p>All treatments taken as 8 inhalations for a total dose of 800 µg BDP, 48 µg FF, 100 µg GB</p>	CHF 5993 DPI (2 inhalations bid; total daily dose: 400 µg BDP, 24 µg FF, 50 µg GB)
Subjects/patients	Healthy adults	Adults with moderate to severe COPD
Number of randomised	50	366
Comparators and total dose	<p>CHF 5993 pMDI with or without CB; CHF 5993 pMDI with or without CB (replicate); CHF 5993 pMDI using a VHC with or without CB</p> <p>All treatments taken as 8 puffs for a total dose of 800 µg BDP, 48 µg FF, 100 µg GB</p>	<p>CHF 5993 pMDI (2 puffs bid; total daily dose: 400 µg BDP, 24 µg FF, 50 µg GB); CHF 1535 pMDI (2 puffs bid; total daily dose: 400 µg BDP, 24 µg FF)</p>
Treatment duration	Single dose	4 weeks

2.6.2. Clinical pharmacology

2.6.2.1. Pharmacokinetics

The main objective of the PK study CCD-05993BA1-01 was to assess whether total systemic exposure (without charcoal blockage [CB]) and pulmonary availability (with CB) following administration of two new formulations (CHF5993 100/6/12.5 µg DPI, T1 and T2) is bioequivalent to the approved formulation (CHF5993 100/6/12.5 µg pMDI, with and without spacer [valved holding chamber]) if the same single, but suprathereapeutic total dose is administered in healthy volunteers of both gender.

Title

Clinical pharmacology study to evaluate the total systemic exposure and the lung availability of CHF 5993, administered via the multi-dose reservoir NEXThaler Dry Powder Inhaler and via a HFA-pressurised Metered Dose Inhaler with and without valved holding chamber, in healthy volunteers (study identification No. CCD-05993BA1-01, EUDRACT No. 2015-005198-19).

Overall study design and sample size

Phase I study, single-centre, two parallel cohorts, randomised, open-label, single-dose, partially-replicated, 5-way cross-over in healthy male and female volunteers. In order to have 40 evaluable subjects, a total of 50 healthy volunteers (at least 19 females and 19 males) were to be randomised.

Figure 2: Cohort 1 without CB

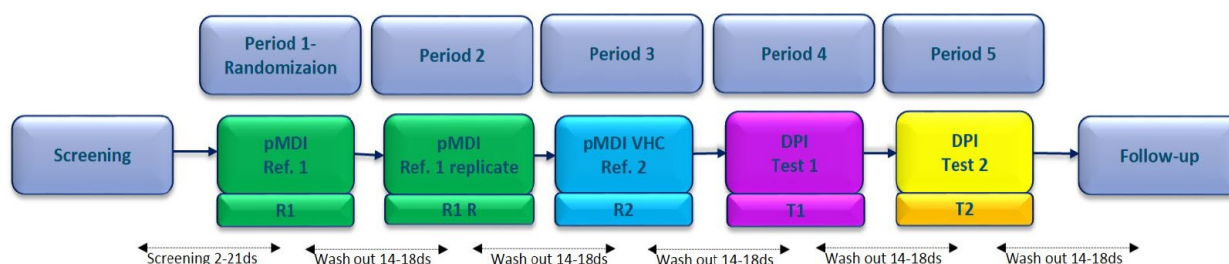
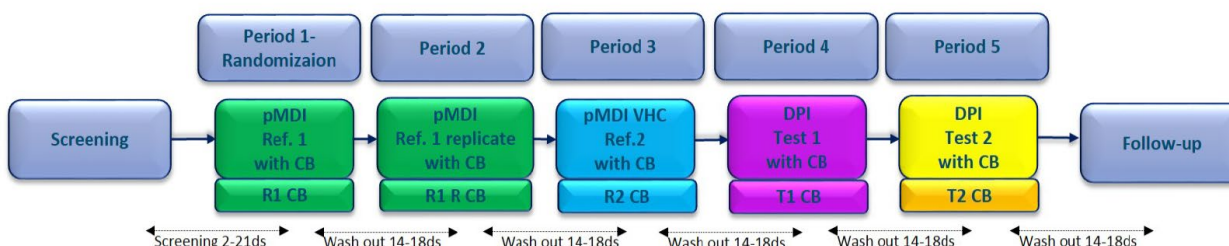

Figure 3: Cohort 1 with CB



Treatments, test and reference products

The following five treatments were administered:

- Treatment R1: single dose administration (8 inhalations) of CHF 5993 100/6/12.5 µg via **pMDI**, giving a total dose of 800 µg BDP, 48µg FF and 100 µg of GB
- Treatment R1 R: single dose administration (8 inhalations) of CHF 5993 100/6/12.5 µg via **pMDI**, giving a total dose of 800 µg BDP, 48 µg FF and 100 µg of GB
- Treatment R2: single dose administration (8 inhalations) of CHF 5993 100/6/12.5 µg via **pMDI**

with VHC, giving a total dose of 800 µg BDP, 48 µg FF and 100 µg of GB

- Treatment T1: single dose administration (8 inhalations) of CHF 5993 100/6/12.5 µg via **DPI** (formulation 1), giving a total dose of 800 µg BDP, 48 µg FF and 100 µg of GB
- Treatment T2: single dose administration (8 inhalations) of CHF 5993 100/6/12.5 µg via **DPI** (formulation 2), giving a total dose of 800 µg BDP, 48 µg FF and 100 µg of GB

Supratherapeutic doses (i.e. fourfold the intended clinical dose) were administered in the mornings in order to achieve sufficient and measurable plasma concentrations. All administrations were performed under fasted conditions. A wash-out period of 14 to 18 days had to be respected between two consecutive administrations.

Primary objective

- To evaluate the total systemic exposure of B17MP (beclometasone 17-monopropionate, active metabolite of beclometasone dipropionate [BDP]), formoterol and glycopyrronium bromide (GB), as area under the plasma concentration-time curve observed from administration up to the last measurable concentration (AUC_{0-t}) and maximum concentration (C_{max}), after administration of two different formulations of CHF 5993 (100/6/12.5 µg) DPI, in comparison with CHF 5993 (100/6/12.5 µg) pressurised metered dose inhaler (pMDI) (with/without valved holding chamber [VHC]).
- To evaluate the pulmonary availability of B17MP, formoterol and GB, assessed as systemic exposure (AUC_{0-t} and C_{max}) upon gastrointestinal charcoal blockage (CB), after administration of two different formulations of CHF 5993 (100/6/12.5 µg) DPI, in comparison with CHF 5993 (100/6/12.5 µg) pMDI (with/without VHC).

Primary PK variables

The primary analysis was based on B17MP (the active metabolite of BDP and not the parent compound), FF and GB.

- B17MP, FF, GB: AUC_{0-t} , C_{max}

Subject disposition and demographic

Twenty-five subjects were randomised to one of the five treatment sequences in Cohort 1 and Cohort 2, i.e., 5 subjects per treatment sequence. All randomised and treated subjects completed the study. No subjects discontinued the study. No major protocol deviations were reported during the study.

All subjects (100%) in Cohort 1 were White. The majority of subjects was male (60.0%). The subjects' mean (SD) age was 40.5 (10.2) years. Their mean (SD) BMI was 25.72 (3.13) kg/m². All subjects (100%) in Cohort 2 were White. The majority of subjects was male (60%). The subjects' mean (SD) age was 42.2 (11.0) years. Their mean (SD) BMI was 24.60 (3.29) kg/m².

Results of the inferential statistics for B17MP, FF and GB and variables (AUC_{0-t} and C_{max})

B17MP

Table 10: Statistical comparison of PK parameters for B17MP between treatments for Cohorts 1 and 2, PK population

	R1 vs. R1R	T1 vs. R1/R1R	T2 vs. R1/R1R	T1 vs. R2	T2 vs. R2
Ratio PE (90% CI) ^a					
Cohort 1 (without charcoal block)					
C _{max} (pg/mL)	99.53 (88.38; 112.08)	90.69 (81.52; 100.91)	82.52 (74.10; 91.91)	53.21 (47.98; 59.00)	48.41 (43.99; 53.29)
AUC _{0-t} (pg.h/mL)	95.87 (87.99; 104.45)	89.48 (82.64; 96.87)	84.22 (78.32; 90.57)	99.66 (90.94; 109.21)	93.80 (86.93; 101.22)
AUC _{0-30min} (pg.h/mL)	NA	71.95 (63.18; 81.95)	66.27 (57.37; 76.54)	40.62 (36.79; 44.86)	37.41 (32.62; 42.91)
AUC _{0-∞} (pg.h/mL)	NA	90.13 (83.43; 97.37)	84.88 (79.06; 91.13)	99.49 (91.32; 108.40)	93.70 (87.50; 100.33)
t _{max} (h)	NA	0.17 (0.13; 0.25)	0.25 (0.13; 0.50)	0.33 (0.25; 0.33)	0.33 (0.33; 0.75)
t _{1/2} (h)	NA	107.08 (100.75; 113.80)	103.09 (96.64; 109.97)	116.24 (109.14; 123.81)	111.91 (105.10; 119.16)
Cohort 2 (with charcoal block)					
C _{max} (pg/mL)	100.36 (86.05; 117.06)	116.91 (98.19; 139.21)	86.55 (74.24; 100.91)	54.28 (48.28; 61.04)	40.40 (35.41; 46.10)
AUC _{0-t} (pg.h/mL)	101.46 (89.70; 114.76)	157.90 (137.88; 180.83)	107.61 (95.18; 121.66)	89.31 (80.89; 98.60)	61.08 (54.88; 67.99)
AUC _{0-30min} (pg.h/mL)	NA	91.72 (76.84; 109.48)	73.97 (63.11; 86.71)	41.79 (36.23; 48.19)	33.86 (29.77; 38.52)
AUC _{0-∞} (pg.h/mL)	NA	153.94 (134.95; 175.61)	108.22 (96.06; 121.91)	89.75 (81.40; 98.96)	63.27 (57.25; 69.91)
t _{max} (h)	NA	0.29 (0.25; 0.33)	0.28 (0.25; 0.33)	0.33 (0.25; 0.33)	0.33 (0.25; 0.33)
t _{1/2} (h)	NA	115.81 (109.67; 122.29)	102.91 (98.09; 107.97)	106.85 (101.52; 112.46)	94.95 (88.29; 102.12)

R1: CHF 5993 100/6/12.5 µg pMDI; R1R: CHF 5993 100/6/12.5 µg pMDI (replicate); R2: CHF 5993 100/6/12.5 µg pMDI with VHC; T1: CHF 5993 100/6/12.5 µg DPI form 1; T2: CHF 5993 100/6/12.5 µg DPI form 2

Formoterol

Table 11: Statistical comparison of PK parameters for formoterol between treatments for Cohorts 1 and 2, PK population

	R1 vs. R1R	T1 vs. R1/R1R	T2 vs. R1/R1R	T1 vs. R2	T2 vs. R2
Ratio PE (90% CI) ^a					
Cohort 1 (without charcoal block)					
C _{max} (pg/mL)	103.37 (94.38; 113.21)	171.10 (150.71; 194.26)	161.56 (142.88; 182.68)	94.58 (84.34; 106.07)	89.98 (81.18; 99.74)
AUC _{0-t} (pg.h/mL)	94.67 (87.09; 102.91)	121.65 (110.61; 133.79)	122.32 (113.43; 131.91)	106.98 (95.78; 119.49)	108.17 (98.88; 118.33)
AUC _{0-30min} (pg.h/mL)	NA	173.09 (150.28; 199.36)	163.71 (142.43; 188.17)	93.65 (83.72; 104.76)	89.71 (80.23; 100.31)
AUC _{0-∞} (pg.h/mL)	NA	124.04 (112.74; 136.46)	121.89 (112.95; 131.73)	108.49 (96.84; 121.55)	107.18 (97.96; 117.27)
t _{max} (h)	NA	0.00 (0.00; 0.00)	0.00 (0.00; 0.00)	0.00 (0.00; 0.00)	0.00 (0.00; 0.00)
t _{1/2} (h)	NA	109.32 (100.58; 118.82)	105.57 (96.73; 115.21)	98.43 (92.45; 104.79)	95.08 (89.35; 101.19)
Cohort 2 (with charcoal block)					
C _{max} (pg/mL)	96.39 (83.42; 111.38)	227.16 (193.97; 266.03)	178.83 (154.50; 207.00)	102.81 (90.34; 117.00)	80.94 (71.40; 91.75)
AUC _{0-t} (pg.h/mL)	96.84 (80.07; 117.12)	236.30 (195.48; 285.65)	185.29 (155.53; 220.74)	100.13 (90.85; 110.37)	78.52 (70.71; 87.19)

AUC _{0-30min} (pg.h/mL)	NA	223.81 (192.10; 260.76)	178.23 (154.64; 205.42)	100.37 (88.78; 113.47)	79.86 (70.41; 90.58)
AUC _{0-∞} (pg.h/mL)	NA	194.05 (170.87; 220.38)	152.01 (132.44; 174.48)	99.20 (91.84; 107.15)	73.21 (68.38; 78.38)
t _{max} (h)	NA	0.00 (0.00; 0.00)	0.00 (0.00; 0.00)	0.00 (0.00; 0.00)	0.00 (0.00; 0.00)
t _{1/2} (h)	NA	108.94 (100.08; 118.59)	102.65 (94.75; 111.22)	93.84 (87.82; 100.28)	89.39 (81.74; 97.76)

R1: CHF 5993 100/6/12.5 µg pMDI; R1R: CHF 5993 100/6/12.5 µg pMDI (replicate); R2: CHF 5993 100/6/12.5 µg pMDI with VHC; T1: CHF 5993 100/6/12.5 µg DPI form 1; T2: CHF 5993 100/6/12.5 µg DPI form 2

Glycopyrronium Bromide

Table 12: Statistical comparison of PK parameters for GB between treatments for Cohorts 1 and 2, PK population

	R1 vs. R1R	T1 vs. R1/R1R	T2 vs. R1/R1R	T1 vs. R2	T2 vs. R2
Ratio PE (90% CI) ^a					
Cohort 1 (without charcoal block)					
C _{max} (pg/mL)	98.00 (84.94; 113.06)	260.05 (212.57; 318.14)	223.84 (189.04; 265.04)	148.42 (113.58; 193.95)	127.38 (105.31; 154.07)
AUC _{0-t} (pg.h/mL)	100.76 (89.22; 113.79)	107.33 (92.99; 123.88)	108.81 (97.44; 121.50)	70.39 (60.31; 82.16)	70.81 (62.22; 80.58)
AUC _{0-30min} (pg.h/mL)	NA	232.94 (192.04; 282.55)	203.51 (172.58; 239.99)	122.79 (96.94; 155.53)	106.45 (90.62; 125.04)
t _{max} (h)	NA	0.00 (0.00; 0.00)	0.00 (0.00; 0.00)	0.00 (0.00; 0.00)	0.00 (0.00; 0.00)
Cohort 2 (with charcoal block)					
C _{max} (pg/mL)	105.99 (84.67; 132.68)	384.95 (314.88; 470.61)	291.40 (238.34; 356.27)	170.61 (140.98; 206.48)	132.66 (109.03; 161.41)
AUC _{0-t} (pg.h/mL)	118.70 (98.58; 142.92)	153.85 (133.29; 177.58)	122.91 (106.22; 142.23)	74.39 (67.81; 81.62)	60.13 (54.63; 66.19)
AUC _{0-30min} (pg.h/mL)	NA	328.77 (274.20; 394.19)	251.09 (209.77; 300.56)	139.11 (117.91; 164.13)	109.52 (92.91; 129.11)
t _{max} (h)	NA	0.00 (-0.04; 0.00)	-0.04 (-0.04; 0.00)	0.00 (0.00; 0.00)	0.00 (0.00; 0.00)

R1: CHF 5993 100/6/12.5 µg pMDI; R1R: CHF 5993 100/6/12.5 µg pMDI (replicate); R2: CHF 5993 100/6/12.5 µg pMDI with VHC; T1: CHF 5993 100/6/12.5 µg DPI form 1; T2: CHF 5993 100/6/12.5 µg DPI form 2

Based on the results from the PK study, Formulation 2 showed the most comparable PK profiles to the reference product (CHF 5993 pMDI). Therefore, this test formulation was selected to be used in the proposed PD study.

2.6.2.2. Pharmacodynamics

No new pharmacodynamics studies were submitted as part of this application.

2.6.3. Discussion on clinical pharmacology

The results of the PK study and how to move to the next step of the clinical investigation were discussed with CHMP/SAWP in 2017 (EMA/H/SA/3068/1/2015/III, EMA/CHMP/SAWP/432923/2017).

Pharmacokinetics

The PK properties of the three actives substances in Trydonis are well known in the COPD population. Thus, no new data have been provided, and are not required, in relation to the PK properties for the actives individually or in a fixed-dose combination (FDC).

Analytical methods have been already assessed within the initial MAA. All bioanalytical analysis presented within this application were performed at the same certified bioanalysis facility. The analytical methods employed have been satisfactorily validated. Evidence of stability of the drug substances in plasma samples has been provided.

To support the clinical development of Trydonis DPI, the MAH conducted a PK study to investigate the test product (Trydonis DPI) in two different formulations (Formulation 1 and Formulation 2) and to identify a DPI formulation with the most comparable PK profile to Trydonis pMDI. Both total systemic exposure (without charcoal block, CB) and pulmonary deposition (with charcoal block, CB) were evaluated. Among the two tested formulations of Trydonis DPI, the one referred to as Formulation 2 shows the most comparable PK profiles to Trydonis pMDI.

However, formulation 2 does not show a fully comparable PK profile for the different active components. The total systemic exposure of the **FF** (C_{max} Ratio T2 vs. R1/R1R 161.56 [90% CI 142.88; 182.68]; AUC_{0-t} Ratio T2 vs. R1/R1R 122.32 [90% CI 113.43; 131.91]) and **GB** (C_{max} Ratio T2 vs. R1/R1R 223.84 [90% CI 189.04; 265.04]) components as a surrogate for safety were substantially higher with Trydonis DPI as compared to Trydonis pMDI without Spacer, while the pulmonary deposition of the active metabolite of **BDP(B17MP)** (C_{max} Ratio T2 vs. R1/R1R 86.55 [90% CI 74.24; 100.91]) component as a surrogate for efficacy was lower (for the peak concentration only) with Trydonis DPI as compared to the Trydonis pMDI without Spacer.

When comparing formulation 2 and Trydonis pMDI with Spacer, the total systemic exposure of **GB** (C_{max} Ratio T2 vs. R2 127.38 [90% CI 105.31; 154.07]) component only was higher with Trydonis DPI.

The approved SmPC of Trydonis pMDI stipulates that Trydonis pMDI may be used either alone or in conjunction with an Aerochamber Plus spacer as both these modes of administration were deemed to be safe by CHMP. Therefore, the clinical data which supported the Trydonis pMDI approval and were generated both with and without a spacer could be used to establish safety and efficacy for the DPI formulation.

Nonetheless it is important to note that the inhalation of Trydonis pMDI with the Aerochamber Plus spacer resulted in an increase in GB total systemic exposure as C_{max} and AUC_{0-t} were substantially higher after inhalation of Trydonis pMDI with spacer compared to inhalation without spacer, with point estimates (90% CI) of the ratios of 160.4% (131.5-195.7%) and 144.8% (127.4-164.6%), respectively (Study TRIPLE 4).

It is also noted, that the Trydonis pMDI clinical development in COPD included a study dedicated to assess the cardio-vascular (CV) safety, the CARSAF study. This study was designed to support the cardiac safety evaluations planned in Phase III studies. CARSAF was a randomized, double-blind, active-controlled, 3-arm parallel group, study to carefully evaluate the cardiac safety of supratherapeutic doses of GB pMDI administered concurrently to Foster pMDI. The study randomized 191 patients with moderate to severe COPD. The results showed that a 14-day treatment with two inhalations of GB 12.5 micrograms twice daily (i.e. total daily dose: 50 µg GB) or two inhalations of 25 micrograms twice daily (i.e. total daily dose: 100 µg GB) on top of Foster was not associated with an increased risk of a raised HR (measured by means of 24-hour digital 12 leads Holter) compared with Foster alone.

Following strictly the 'Requirements for clinical documentation for orally inhaled products (OIP) including the requirements for demonstration of therapeutic equivalence between two inhaled products for use in the treatment of asthma' Guideline, a PD safety study focusing on the safety of the GB component, particularly on cardiovascular safety, would be required. It was noted that in previous studies with GB pMDI, GB did not show any clinically relevant effect on CV parameters, in particular on HR_{0-4h}. In particular, in GLYCO 2 study the difference between GB and Placebo in HR_{0-4h} (mean of three post-treatment HR values, post-hoc analysis) was equal to 0 (-0.3 bpm with GB 50 µg, +0.1 bpm with GB 25 µg and GB 100 µg). The lack of GB effect was also observed when HR was evaluated during the 12 hours post-treatment (difference between GB and placebo did not exceed 1 bpm at any dose). Thus, the applicant was advised that the initially proposed PD safety study with the primary endpoint HR_{0-4h} at Day 7 would not be able to discriminate between the GB dose of one formulation and another.

Due to the fact that an appropriate PD study could not be designed to address potential systemic safety concerns, the Applicant has proposed a post-marketing safety study (PASS) to assess the incidence of cardiovascular outcomes among new users of Trimbow DPI with COPD using 'major adverse cardiovascular events' as primary outcome to address the PK differences in GB. CHMP/SAWP concluded that the sensitivity of such a study would be regarded to be low but may be acceptable as the only means of addressing the long-term GB-exposure related safety concern. The duration of the PASS study was extended to 5 years upon request by CHMP.

With regard to efficacy, the MAH considered that due to the flat dose-response curve of BDP, there are no concerns on the efficacy for this component of DPI as compared to the pMDI. For FF and GB, the MAH considered that there are no efficacy concerns as there is a higher exposure. However, given the difference seen in PK (in general higher exposures as compared to pMDI and in particular differences in C_{max} which suggest a difference in lung distribution for FF and GB, and lower exposure of BDP/B17MP), CHMP/SAWP raised concerns regarding efficacy and the contribution of each component. While this may not be an issue for an inhaler with one active substance; for a fixed dose combination particularly where two bronchodilators are included it is important that the dose of each individual component is appropriate such that there is clinically meaningful contributory effect of each component. In addition, as both FF and GB are bronchodilators, it is conceivable that the pulmonary exposure of each component should be appropriate for a clinically meaningful contribution to the combination.

CHMP/SAWP finally agreed on Applicant's proposed strategy to perform a double-blind, randomized, 3-way cross-over, 4-week active controlled PD efficacy study in COPD patients with two co-primary endpoints FEV1 AUC_{0-12h} and trough FEV1 at 24 hours at the end of treatment period at week 4 to demonstrate (i) non-inferiority of Trydonis DPI vs Trydonis pMDI (NI margin of 50ml) and (ii) superiority of Trydonis DPI vs Foster DPI.

Pharmacodynamics

The pharmacodynamics of the three active substances in Trydonis have been previously characterised in the COPD population. The lack of new PD studies is therefore acceptable. The relevant sections of the proposed SmPC contain the appropriate information.

2.6.4. Conclusions on clinical pharmacology

The PK properties of the three actives substances contained in Trimbow are well known in the COPD population. However, to support the clinical development programme of Trimbow DPI new device, a PK study was performed in accordance with the OIP guideline. However, there were some PK differences seen between the two formulations (DPI/pMDI). While the total systemic exposure of FF and GB were substantially higher with Trimbow DPI as compared to Trimbow pMDI, the pulmonary deposition of the

active metabolite of BDP (B17MP) was lower (for the peak concentration only) with Trimbow DPI as compared to the Trimbow pMDI without Spacer. To address the potential impact on safety due to the higher exposure seen with the FF and GB, a PASS will be performed by the MAH in the post-marketing setting which is acceptable.

With regard to efficacy and demonstration of therapeutic equivalence between the devices, a phase II PD efficacy study has been performed by the MAH to demonstrate the non-inferiority of Trimbow DPI vs Trimbox pMDI and is further discussed below.

2.6.5. Clinical efficacy

2.6.5.1. Main study

In order to address the potential concerns from the above PK differences, the Applicant has conducted the TRI-D study.

Title of study

A phase II, multicentre, randomised, double-blind, double-dummy, active-controlled, 3-way cross-over study to evaluate the efficacy of CHF 5993 administered via Dry Powder Inhaler (DPI) versus CHF 5993 via pressurized Metered Dose Inhaler (pMDI) and CHF 1535 pMDI in patients with chronic obstructive pulmonary disease (Study identification No. CLI-05993BA1-02, EUDRACT No. 2017-004405-41)

Methods

This was a phase II, multicentre, randomised, double-blind, double-dummy, active-controlled, 3-way cross-over study in patients with chronic obstructive pulmonary disease (COPD). The study aimed to demonstrate the non-inferiority between CHF 5993 DPI versus (vs.) CHF 5993 pMDI in terms of lung function after 4 weeks of treatment (changes from baseline in FEV1 AUC0-12h normalised by time and trough FEV1 at 24 hours on Day 28).

- **Study design**

Figure 4: General study design flowchart

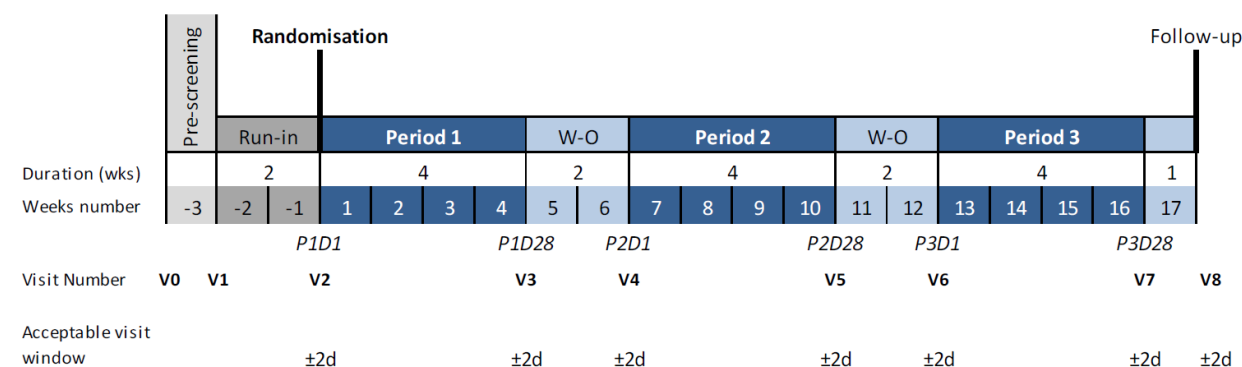

Days (d); PXDX (Period X Day X); Visit (V); Wash-out (W-O); Weeks (wks)

The study comprised eight visits and a follow-up call. A pre-screening visit (Visit [V] 0) was planned to occur no more than 7 days prior to screening (V1, Week -2) and was followed by a 2-week open-label run-in period of CHF 1535 pMDI 100/6 µg, 2 puffs twice daily (BID) (i.e. total daily dose: 400/24 µg beclometasone dipropionate [BDP]/formoterol fumarate [FF]).

Superiority of CHF 5993 pMDI to CHF 1535 pMDI was tested to demonstrate assay sensitivity. CHF 1535 pMDI was chosen as reference treatment, as it is currently marketed for the treatment of COPD patients who have significant symptoms despite long-acting bronchodilator therapy. CHF 1535 pMDI was used in this study at the marketed dose (BDP/FF 100/6 µg per actuation).

Each 4-week treatment period was separated by a 2-week wash-out period, during which patients received CHF 1535 pMDI 100/6 µg as during the run-in (i.e. 2 puffs BID; total daily dose: 400/24 µg BDP/FF). A 2-week wash-out period between treatment periods was considered sufficient to avoid carry-over effects of treatment during the study. The 4-week treatment period allowed adequate assessment of efficacy variables.

During each treatment period, visits were scheduled on Day 1 (V2, V4 and V6) and Day 28 (V3, V5 and V7). An early termination (ET) visit, during which all the assessments foreseen at V7 should have been done, was performed in the event of premature study discontinuation. A follow-up phone call was performed 1 week after the last visit (or after the ET visit).

• **Study Participants**

Eligible patients included male and female patients aged ≥ 40 and ≤ 85 years with a diagnosis of COPD established according to the Global Initiative for Obstructive Lung Disease document updated 2017 at least 12 months prior to screening. Patients had to have a post-bronchodilator FEV1 $\geq 30\%$ and $< 80\%$ of the predicted normal value and a post-bronchodilator FEV1/forced vital capacity < 0.7 , and a smoking history of at least 10 pack-years. Current and ex-smokers were eligible. For ex-smokers, smoking cessation must have been completed more than 6 months prior to screening.

Previous medication: patients' COPD therapy at screening with either:

- a. ICS/LABA/LAMA (free or fixed) combination;
- b. ICS/LABA (free or fixed) combination;
- c. Inhaled LABA/LAMA (free or fixed) combination;
- d. Inhaled LAMA.

• **Treatments**

At the randomisation visit (V2, Week 0), patients were randomised to receive the following treatments, each for a duration of 4 weeks, according to a particular sequence:

- CHF 5993 DPI 100/6/12.5 µg, 2 inhalations BID (total daily dose: 400/24/50 µg BDP/FF/glycopyrronium bromide [GB]);
- CHF 5993 pMDI 100/6/12.5 µg, 2 puffs BID (total daily dose: 400/24/50 µg BDP/FF/GB);
- CHF 1535 pMDI 100/6 µg, 2 puffs BID (total daily dose: 400/24 µg BDP/FF).

• **Objectives**

Primary Objectives:

- To demonstrate the non-inferiority between CHF 5993 dry powder inhaler (DPI) and CHF 5993 pressurised metered dose inhaler (pMDI) in terms of forced expiratory volume in the 1st second (FEV1) area under the curve between 0 and 12 hours (AUC0-12h) normalised by time on Day 28;
- To demonstrate the non-inferiority between CHF 5993 DPI and CHF 5993 pMDI in terms of trough FEV1 at 24 hours on Day 28;

The AUC_{0-12h} was selected since it measures the aggregate effect over the full 12-hour dosing interval suitable for a BID dosing regimen using serial post-dose FEV₁ assessments. The trough FEV₁, measured at 24 hours post-dose was selected to ensure that the LABA and LAMA (FF and GB) components did not mask any potential differences in the ICS (BDP) between the DPI and pMDI formulations.

Importantly, centralised spirometry was used to improve data quality.

Secondary Objectives:

- To evaluate the efficacy of CHF 5993 DPI on other lung function parameters and clinical outcome measures;
- To evaluate the safety and tolerability of the study treatments.
- **Outcomes/endpoints**

Efficacy:

Primary efficacy variables:

- Change from baseline in FEV₁ AUC_{0-12h} normalised by time (L) on Day 28;
- Change from baseline in trough FEV₁ at 24 hours (L) on Day 28.

Secondary efficacy variables:

- Change from baseline in pre-dose morning FEV₁ (L) on Day 28;
- Change from baseline in FEV₁ area under the curve between 0 and 4 hours (AUC_{0-4h}) normalised by time (L) on Day 28;
- Change from baseline in FEV₁ AUC_{0-12h} normalised by time (L) on Day 1;
- Change from baseline in peak FEV₁ up to 12 hours (L) on Day 28 and Day 1;
- Responder analysis on the change from baseline in pre-dose morning FEV₁ response (change from baseline in pre-dose morning FEV₁ \geq 100 mL) on Day 28;
- Change from baseline in the St. George's Respiratory Questionnaire (SGRQ) total score and domain scores on Day 28;
- Percentage of days without intake of rescue medication and average use of rescue medication (puffs/day).

Safety:

- Adverse events (AEs) and adverse drug reactions (ADRs);
- Vital signs (systolic blood pressure [SBP] and diastolic blood pressure [DBP]);
- 12-lead electrocardiogram (ECG) parameters: heart rate (HR), Fridericia's corrected QT interval (QTcF), PR interval (PR) and QRS interval (QRS).
- **Sample size**

It was planned to randomise a total of 354 patients (59 per sequence) in accordance with the inclusion and exclusion criteria, in order to reach a total of 301 completed and evaluable patients considering a non-evaluable rate of approximately 15%.

- **Randomisation and Blinding (masking)**

A balanced block randomisation scheme was prepared via a computerised system. At V2 (Week 0) patients were centrally assigned to one of six treatment sequences, arranged according to a complete set of 3 x 3 Latin Squares, through an IRT system using the lowest available randomisation number.

In order to ensure the double-blind study design for the same period, patients receiving CHF 5993 DPI active were administered CHF 5993 pMDI placebo. Similarly, patients receiving CHF 5993 pMDI or CHF 1535 pMDI were administered CHF 5993 DPI placebo. Patients started with DPI treatment then continued with pMDI treatment. Each day during the treatment periods patients administered 2 inhalations from the first DPI and 2 puffs from the first pMDI in the morning, then 2 inhalations from the second DPI and 2 puffs from the second pMDI in the evening.

- **Statistical methods**

Since a cross-over design was used, inclusion in the analysis sets was defined on a per-period basis. The following analysis sets were considered for analysis:

- Safety set defined as all randomised patients who received at least one dose of study treatment;
- Intention-to-treat (ITT) set defined as all randomised patients who received at least one dose of study treatment and with at least one available evaluation of efficacy (primary or secondary efficacy variables) after the baseline;
- Per-protocol (PP) set defined as all patients from the ITT set without any major protocol deviations (i.e. wrong inclusions, poor compliance, non-permitted medications).

Analyses of the primary efficacy variables were based on the ITT and PP sets. In the non-inferiority comparisons between CHF 5993 DPI and CHF 5993 pMDI, the ITT and PP sets had equal importance, while the superiority comparison between CHF 5993 pMDI and CHF 1535 pMDI in terms of FEV1 AUC0-12h normalised by time on Day 28 was based on the ITT set. This superiority comparison was also performed on the PP set for sensitivity purposes.

Analyses of the secondary variables were based on the ITT set. The safety variables were analysed in the Safety set.

Efficacy analysis

The comparisons between CHF 5993 DPI, CHF 5993 pMDI and CHF 1535 pMDI in terms of the primary efficacy variables were conducted according to a hierarchical testing procedure. The primary efficacy comparisons were considered in the following order:

- Non-inferiority testing of CHF 5993 DPI vs. CHF 5993 pMDI in terms of FEV1 AUC0-12h normalised by time on Day 28;
- Superiority testing of CHF 5993 pMDI vs. CHF 1535 pMDI in terms of FEV1 AUC0-12h normalised by time on Day 28, in order to establish assay sensitivity;
- Non-inferiority testing of CHF 5993 DPI vs. CHF 5993 pMDI in terms of trough FEV1 at 24 hours on Day 28.

Primary efficacy variables

FEV1 AUC0-12h normalised by time on Day 28 was calculated based on the actual times using the linear trapezoidal rule. The corresponding change from baseline in FEV1 AUC0-12h normalised by time on Day 28 was analysed using an analysis of covariance with treatment, period and patient as fixed effects and baseline FEV1 value as a covariate.

The adjusted treatment means, adjusted mean difference between treatments with associated 95% two-sided confidence intervals (CIs) and corresponding p-values were estimated by the model. Non-inferiority of CHF 5993 DPI vs. CHF 5993 pMDI was claimed if the two-sided 95% CI of the adjusted mean difference between treatments lay entirely to the right of the pre-defined non-inferiority margin of -50 mL. Provided that the non-inferiority had been claimed, the assay sensitivity was to be evaluated by comparing CHF 5993 pMDI to CHF 1535 pMDI. Assay sensitivity was to be demonstrated by a statistically significant difference ($p < 0.05$) between treatments in favour of CHF 5993 pMDI vs. CHF 1535 pMDI.

Trough FEV1 at 24 hours on Day 28 was calculated as the mean of the two measurements at 23.5 hours and 24 hours post-dose. Change from baseline in trough FEV1 at 24 hours on Day 28 was analysed using the same model as for FEV1 AUC0-12h normalised by time on Day 28. Non-inferiority of CHF 5993 DPI vs. CHF 5993 pMDI was to be claimed if the two-sided 95% CI of the adjusted mean difference between treatments lay entirely to the right of the pre-defined non-inferiority margin of -50 mL. Comparisons of CHF 5993 pMDI vs. CHF 1535 pMDI and CHF 5993 DPI vs. CHF 1535 pMDI were also presented.

Secondary efficacy variables

- The same model as for the primary efficacy analysis was used for the following secondary efficacy analysis. The adjusted means for each treatment and the adjusted mean difference between treatments and their 95% CIs and p-values were estimated by the model:
 - Change from baseline in pre-dose morning FEV1 (L) on Day 28;
 - Change from baseline in FEV1 AUC0-4h normalised by time (L) on Day 28;
 - Change from baseline in FEV1 AUC0-12h normalised by time (L) on Day 1;
 - Change from baseline in peak0-12h FEV1 (L) on Day 28 and Day 1;
- FEV1 response (change from baseline in pre-dose morning FEV1 ≥ 100 mL) on Day 28 was analysed using a conditional logistic regression model with treatment and period as fixed effects, patient as strata and baseline FEV1 as covariate. The odds ratio for the treatment effect CHF 5993 DPI vs. CHF 5993 pMDI, CHF 5993 pMDI vs. CHF 1535 pMDI and CHF 5993 DPI vs. CHF 1535 pMDI with their 95% CIs and corresponding p-values were estimated by the model;
- Changes from baseline in SGRQ total and domain (symptoms, impacts and activity) scores were analysed using the same model as for the primary efficacy analysis. However, baseline SGRQ total score (or specific domain score) was included as a covariate instead of baseline FEV1;
- The percentage of days without intake of rescue medication was analysed using an analysis of variance (ANOVA) model with treatment, period, and patient as fixed effects. The same descriptive statistics and ANOVA model were performed for the average use of rescue medication during the treatment period. The adjusted treatment means, adjusted mean difference between treatments (i.e. CHF 5993 DPI vs. CHF 5993 pMDI, CHF 5993 pMDI vs. CHF 1535 pMDI and CHF 5993 DPI vs. CHF 1535 pMDI) with their 95% CIs and corresponding p-values were estimated by the model.

Safety analysis

The number of treatment-emergent AEs (TEAEs) and the number and percentage of patients experiencing at least one AE, serious AE (SAE), non-SAE, ADR, serious ADR, severe AE, AE leading to study treatment discontinuation or AE leading to death were summarised overall by treatment and by

treatment, system organ class (SOC) and preferred term using the Medical Dictionary for Regulatory Activities dictionary (version 21.0).

Vital signs (pre-dose SBP and DBP) and their changes from baseline were summarised by treatment using descriptive statistics. The 95% CI for the mean change from baseline was also presented.

The absolute values and the changes from baseline for 12-lead ECG parameters (HR, QTcF, PR and QRS) were summarised by treatment using descriptive statistics and the CI of the mean (95% CI for absolute values and 90% CI for the changes from baseline).

The number and the percentage of patients with any of the following at each timepoint and at any timepoint after Day 1 pre-dose were presented by treatment:

- QTcF > 450 ms, > 480 ms and > 500 ms for males and QTcF > 470 ms and > 500 ms for females;
- Change from baseline in QTcF > 30 ms and > 60 ms;
- Change from pre-dose Day 28 in QTcF > 30 ms and > 60 ms (for Day 28 only).

Results

• Baseline data

Demographic and baseline characteristics were similar across treatment sequences. The majority of patients were male (215 [58.7%] males vs. 151 [41.3%] females overall) and all were white. Overall, the mean age was 64.9 years and mean body mass index (BMI) was 27.6 kg/m².

COPD history and smoking habits were both generally similar across treatment sequences. Overall, the mean time since first COPD diagnosis was 9.5 years and most patients had chronic bronchitis as the most plausible COPD phenotype (196 [53.6%] patients), though this varied across treatment sequences (ranging from 28 [45.2%] to 37 [60.7%] patients).

Most patients were under double or triple therapy prior to study entry (127 [34.7%], 118 [32.2%] and 105 [28.7%] patients overall had been on ICS/LABA/LAMA, ICS/LABA and LABA/LAMA therapy, respectively). Overall, the majority of patients (240 [65.6%] patients) had not had a COPD exacerbation in the previous year, while a large minority had one exacerbation (113 [30.9%] patients) and the mean time since an exacerbation was 12.1 months.

All patients were either current or ex-smokers (185 [50.5%] and 181 [49.5%] patients, respectively), with an overall mean smoking duration of 38.8 years and a mean of 20.0 pack-years. Only 1 (0.3%) patient changed their smoking status during the study (the patient, from treatment sequence CAB, stopped smoking).

• Numbers analysed

The overall safety set included all 366 randomised patients. The overall ITT set included 365 patients. One patient (treated with CHF 5993 pMDI) was excluded from the ITT set since they only performed the 10 minute post-dose spirometry on Day 1 of Period 1 (V2) and then discontinued the study due to family reasons. The overall PP set included 361 patients.

Patients included in the ITT set with major protocol deviations were not included in the PP set. A total of nine (9) (2.5%), eleven (11) (3.1%) and three (3) (0.8%) patients had at least one major protocol deviation with CHF 5993 DPI, CHF 5993 pMDI and CHF 1535 pMDI, respectively.

Non-adequate compliance to the treatment period (defined as compliance < 80% or > 120% during a specific treatment period) occurred in eight (8) (2.3%), ten (10) (2.8%) and two (2) (0.6%) patients

with CHF 5993 DPI, CHF 5993 pMDI and CHF 1535 pMDI, respectively, and was the most commonly reported major protocol deviation. In addition, violation of inclusion criterion was reported in one (1) (0.3%) patient with all treatments (inclusion criterion #5; patient under treatment with ICS/LABA and LABA/LAMA at screening).

Table 13: Data sets analysed by treatment and overall

	CHF 5993 DPI	CHF 5993 pMDI	CHF 1535 pMDI	Overall
Randomised set, n	-	-	-	366
Safety set, n	354	358	357	366
ITT set, n	354	357	357	365
PP set, n	345	346	354	361

Outcomes and estimation

Primary efficacy variables

Change from baseline in FEV1 AUC0-12h (L) on Day 28

In the ITT population, a greater increase in FEV1 AUC0-12h from baseline to Day 28 was observed with BDP/FF/GB DPI and BDP/FF/GB pMDI compared to BDP/FF pMDI, with adjusted mean changes (95% CI) of 0.146 L (0.136; 0.157), 0.167 L (0.156; 0.177) and 0.062 L (0.051; 0.072), respectively (Table 20). The adjusted mean difference (95% CI) between BDP/FF/GB DPI and BDP/FF/GB pMDI was -0.020 L (-0.035; -0.006). Since the 95% CIs are entirely above the pre-defined non-inferiority limit of -0.050 L, the non-inferiority of BDP/FF/GB DPI relative to BDP/FF/GB DPI was demonstrated.

Table 14: Change from baseline in FEV1 AUC0-12h (L) on Day 28, ITT population – TRI-D study

			BDP/FF/GB DPI N=354	BDP/FF/GB pMDI N=357	BDP/FF pMDI N=357
Baseline^a	n		354	357	357
	Mean (SD)		1.315 (0.501)	1.312 (0.480)	1.310 (0.500)
Day 28	Actual values	n	351	351	353
		Mean (SD)	1.462 (0.506)	1.480 (0.517)	1.376 (0.515)
	Change from Baseline	n	351	351	353
		Adj. mean (95% CI)	0.146 (0.136; 0.157)	0.167 (0.156; 0.177)	0.062 (0.051; 0.072)
	BDP/FF/GB DPI vs. BDP/FF/GB pMDI	Adj. mean diff. (95% CI)	-0.020 (-0.035; -0.006)		
		p-value	0.007		
	BDP/FF/GB pMDI vs. BDP/FF pMDI	Adj. mean diff. (95% CI)	0.105 (0.090; 0.120)		
		p-value	< 0.001		
	BDP/FF/GB DPI vs. BDP/FF pMDI	Adj. mean diff. (95% CI)	0.085 (0.070; 0.099)		
		p-value	< 0.001		

Assay sensitivity was established, given the statistically significantly greater increase in FEV1 AUC0-12h with BDP/FF/GB pMDI vs. BDP/FF pMDI with an adjusted mean difference of 0.105 L (95% CI: 0.090; 0.120), $p < 0.001$). In addition, superiority of BDP/FF/GB DPI vs. BDP/FF pMDI was also demonstrated with an adjusted mean difference of 0.085 L (95% CI: 0.070, 0.099), $p < 0.001$.

A clear trend in favour of the two triple treatments compared to BDP/FF pMDI was observed in terms of mean absolute FEV1 values post-dose on Day 28 in the ITT population (Figure 5).

Figure 5: Mean change from baseline in FEV1 values on Day 28, ITT population – TRI-D study

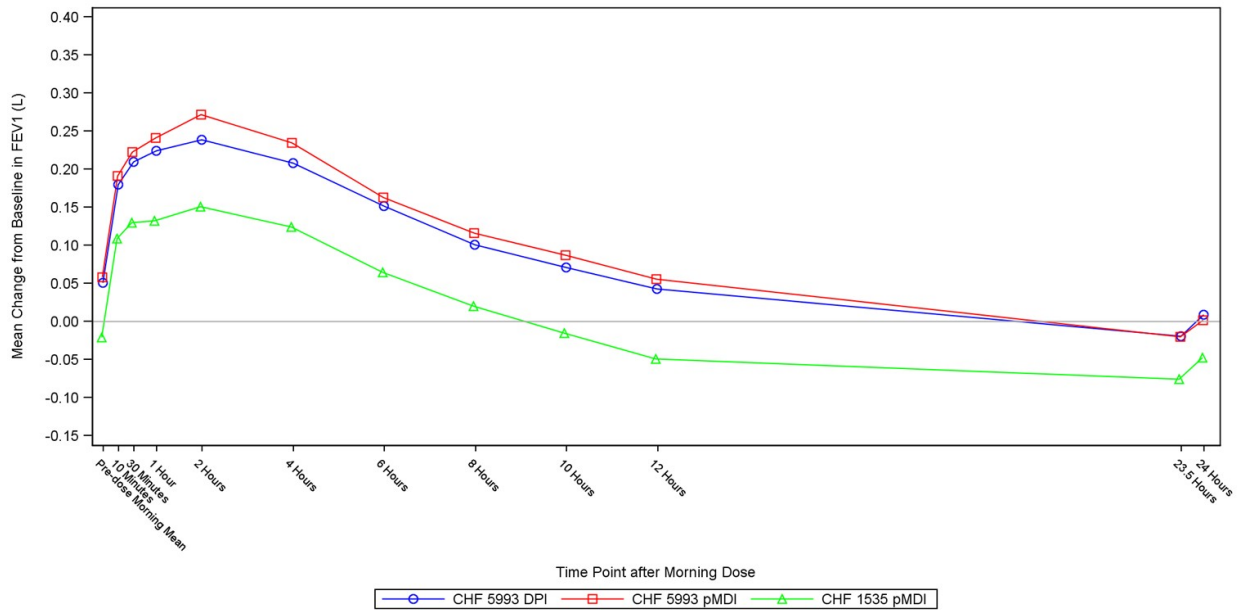

Similarly, in the PP population, a greater increase in FEV₁ AUC_{0-12h} from baseline to Day 28 was observed with BDP/FF/GB DPI and BDP/FF/GB pMDI compared to BDP/FF pMDI. The adjusted mean difference (95% CI) between BDP/FF/GB DPI and BDP/FF/GB pMDI was -0.022 L (-0.037; -0.007). Since the 95% CI are entirely above the non-inferiority limit of -0.050 L, the non-inferiority of BDP/FF/GB DPI relative to BDP/FF/GB pMDI was demonstrated.

Assay sensitivity was considered to be established, given the observed statistically significantly greater increase in FEV₁ AUC_{0-12h} with BDP/FF/GB pMDI vs. BDP/FF pMDI (adjusted mean difference of 0.106 L [95% CI: 0.091; 0.121], p < 0.001) and the superiority of BDP/FF/GB DPI vs. BDP/FF pMDI was also demonstrated (adjusted mean difference of 0.084 L [95% CI: 0.069, 0.099], p < 0.001).

Change from baseline in trough FEV1 (L) at 24 hours on Day 28

There was no noticeable change in trough FEV₁ from baseline to 24 hours on Day 28 in the ITT population with BDP/FF/GB DPI or BDP/FF/GB pMDI (adjusted mean changes [95% CI] of -0.006 L [-0.019; 0.006] and -0.009 L [-0.021; 0.003], respectively) and a decrease with BDP/FF pMDI (-0.063 L [-0.076; -0.051]) (

Table **21**). A similar effect was observed with BDP/FF/GB DPI and BDP/FF/GB pMDI (adjusted mean difference of 0.003 L [95% CI: -0.015; 0.020]). Since the 95% CI of the adjusted mean difference are entirely above the pre-defined non-inferiority limit of -0.050 L, the non-inferiority of BDP/FF/GB DPI relative to BDP/FF/GB pMDI was demonstrated.

Table 15: Change from baseline in trough FEV1 (L) at 24 hours on Day 28, ITT population – TRI-D study

			BDP/FF/GB DPI N=354	BDP/FF/GB pMDI N=357	BDP/FF pMDI N=357
Baseline^a	n		354	357	357
	Mean (SD)		1.315 (0.501)	1.312 (0.480)	1.312 (0.500)
Day 28	Actual values	n	351	350	351
		Mean (SD)	1.310 (0.480)	1.304 (0.496)	1.251 (0.495)
	Change from Baseline	n	351	350	351
		Adj. mean (95% CI)	-0.006 (-0.019; 0.006)	-0.009 (-0.021; 0.003)	-0.063 (-0.076; -0.051)
	BDP/FF/GB DPI vs. BDP/FF/GB pMDI	Adj. mean diff. (95% CI)	0.003 (-0.015; 0.020)		
		p-value	0.749		
	BDP/FF/GB pMDI vs. BDP/FF pMDI	Adj. mean diff. (95% CI)	0.054 (0.037; 0.072)		
		p-value	< 0.001		
	BDP/FF/GB DPI vs. BDP/FF pMDI	Adj. mean diff. (95% CI)	0.057 (0.040; 0.074)		
		p-value	< 0.001		

The adjusted mean difference between BDP/FF/GB DPI and BDP/FF pMDI was statistically significant in favour of BDP/FF/GB DPI (0.057 L [95% CI: 0.040; 0.074], $p < 0.001$) and was of a comparable magnitude to the adjusted mean difference between BDP/FF/GB pMDI and BDP/FF pMDI (0.054 L [95% CI: 0.037; 0.072], $p < 0.001$).

Similarly, in the PP population, no notable change in trough FEV₁ from baseline to Day 28 was observed with BDP/FF/GB DPI and BDP/FF/GB pMDI, while a decrease was observed with BDP/FF pMDI. A similar effect was observed with BDP/FF/GB DPI and with BDP/FF/GB pMDI (adjusted mean difference of 0.003 L [95% CI: -0.015; 0.020]). Since the 95% CI of the adjusted mean difference are entirely above the non-inferiority limit of -0.050 L, the non-inferiority of BDP/FF/GB DPI relative to BDP/FF/GB pMDI was demonstrated.

The adjusted mean difference between BDP/FF/GB DPI and BDP/FF pMDI was statistically significant in favour of BDP/FF/GB DPI (0.057 L [95% CI: 0.040; 0.074], $p < 0.001$) and was of a comparable magnitude to the adjusted mean difference between BDP/FF/GB pMDI and BDP/FF pMDI (0.054 L [95% CI: 0.037; 0.071], $p < 0.001$).

Secondary efficacy variables

Change from baseline in pre-dose morning FEV1 (L) on Day 28

The adjusted mean change in pre-dose morning FEV1 from baseline to Day 28 was an increase with both triple therapies, and a decrease with BDP/FF pMDI (

Table **22**). A similar effect was observed with BDP/FF/GB DPI and BDP/FF/GB pMDI (adjusted mean difference of -0.009 L [95% CI: -0.027; 0.010]). Statistically significantly greater increases in pre-dose morning FEV1 were observed with both triple therapies compared to BDP/FF pMDI (adjusted mean differences [95% CI] of 0.072 L [0.053; 0.090], $p < 0.001$ and 0.081 L [0.062; 0.099], $p < 0.001$ for BDP/FF/GB DPI vs. BDP/FF pMDI and BDP/FF/GB pMDI vs. BDP/FF pMDI, respectively).

Table 16: Change from baseline in pre-dose morning FEV1 (L) on Day 28, ITT population – TRI-D study

			BDP/FF/GB DPI N=354	BDP/FF/GB pMDI N=357	BDP/FF pMDI N=357
Baseline	n		354	357	357
	Mean (SD)		1.315 (0.501)	1.312 (0.480)	1.310 (0.500)
Day 28	Actual values	n	351	352	354
		Mean (SD)	1.366 (0.495)	1.374 (0.500)	1.292 (0.500)
	Change from Baseline	n	351	352	354
		Adj. mean (95% CI)	0.047 (0.034; 0.060)	0.056 (0.043; 0.069)	-0.025 (-0.038; -0.012)
	BDP/FF/GB DPI vs. BDP/FF/GB pMDI	Adj. mean diff. (95% CI)	-0.009 (-0.027; 0.010)		
		p-value	0.363		
	BDP/FF/GB pMDI vs. BDP/FF pMDI	Adj. mean diff. (95% CI)	0.081 (0.062; 0.099)		
		p-value	< 0.001		
	BDP/FF/GB DPI vs. BDP/FF pMDI	Adj. mean diff. (95% CI)	0.072 (0.053; 0.090)		
		p-value	< 0.001		

Change from baseline in SGRQ total score and domain scores on Day

The change from baseline in SGRQ total score was a small decrease (i.e. indicative of an improvement in quality of life) with both BDP/FF/GB DPI and BDP/FF/GB pMDI, and no notable change with BDP/FF pMDI. This was reflected in the adjusted mean differences between treatments with a similar effect observed for the two triple therapies (0.43 [95% CI: -0.60; 1.47] for BDP/FF/GB DPI vs. BDP/FF/GB pMDI), and statistically significantly greater decreases in SGRQ total score with both triple therapies compared to BDP/FF pMDI (adjusted mean differences [95% CI] of -1.08 [-2.12; -0.04], p=0.042 and -1.52 [-2.56; -0.48], p=0.004 for BDP/FF/GB DPI vs. BDP/FF pMDI and BDP/FF/GB pMDI vs. BDP/FF pMDI, respectively).

Percentage of days without intake of rescue medication

The percentage of rescue medication-free days was similar with the two triple therapies BDP/FF/GB DPI and BDP/FF/GB pMDI (adjusted mean difference of 1.64% [95% CI: -0.61; 3.89]. Treatment with both triple therapies resulted in a statistically significantly greater percentage of rescue medication-free days compared to treatment with BDP/FF pMDI (adjusted mean differences [95% CI] of 5.25% [3.01; 7.49], p < 0.001 and 3.61% [1.36; 5.86], p=0.002 for BDP/FF/GB DPI vs. BDP/FF pMDI and BDP/FF/GB pMDI vs. BDP/FF pMDI, respectively).

Average use of rescue medication

The average use of rescue medication was similar with the two triple therapies BDP/FF/GB DPI and BDP/FF/GB pMDI (adjusted mean difference of 0.017 puffs/day [95% CI: -0.077; 0.112]). Treatment with both triple therapies resulted in statistically significantly less rescue medication use compared to treatment with BDP/FF pMDI (adjusted mean differences [95% CI] of -0.149 puffs/day [-0.243; -0.055], p=0.002 and -0.166 puffs/day [-0.261; -0.072], p < 0.001 for BDP/FF/GB DPI vs. BDP/FF pMDI and BDP/FF/GB pMDI vs. BDP/FF pMDI, respectively).

• **Summary of main efficacy results**

The following tables summarise the efficacy results from the main studies supporting the present application. These summaries should be read in conjunction with the discussion on clinical efficacy as well as the benefit risk assessment (see later sections).

Table 17: Summary of efficacy for trial CLI-05993BA1-02

<p>Title: A phase II, multicentre, randomised, double-blind, double-dummy, active-controlled, 3-way cross-over study to evaluate the efficacy of CHF 5993 administered via Dry Powder Inhaler (DPI) versus CHF 5993 via pressurized Metered Dose Inhaler (pMDI) and CHF 1535 pMDI in patients with chronic obstructive pulmonary disease</p>			
Study identifier	CLI-05993BA1-02		
Design	This was a multicentre, randomised, double-blind, double-dummy, active-controlled, 3-way cross-over study		
	Duration of main phase:	Each 4-week treatment period was separated by a 2-week (\pm 2 days) wash-out period. There were three treatment periods	
	Duration of Run-in phase:	2-week open-label run-in period	
Hypothesis	The study aimed to demonstrate non-inferiority between CHF 5993 administered via DPI compared to administration via pMDI in terms of lung function after 4 weeks of treatment.		
Treatments groups	CHF 5993 DPI	CHF 5993 DPI 100/6/12.5 μ g, 2 inhalations BID (total daily dose: 400/24/50 μ g BDP/FF/glycopyrronium bromide [GB]); 4-week treatment; 354 patients	
	CHF 5993 pMDI	CHF 5993 pMDI 100/6/12.5 μ g, 2 puffs BID (total daily dose: 400/24/50 μ g BDP/FF/GB); 4-week treatment; 357 patients	
	CHF 1535 pMDI	CHF 1535 pMDI 100/6 μ g, 2 puffs BID (total daily dose: 400/24 μ g BDP/FF), 4-week treatment; 357 patients	
Endpoints and definitions	Co-Primary endpoint	FEV1 AUC0-12h	Change from baseline in FEV1 AUC0-12h normalised by time (L) on Day 28
	Co-Primary endpoint	trough FEV1 at 24 hours	Change from baseline in trough FEV1 at 24 hours (L) on Day 28.
	Secondary endpoint	pre-dose morning FEV1	Change from baseline in pre-dose morning FEV1 (L) on Day 28;
Database lock	27 June 2019		
Results and Analysis			
Analysis description	Primary Analysis		
Analysis population and time point description	Intent to treat at day 28		

Descriptive statistics and estimate variability	Treatment group	CHF 5993 DPI	CHF 5993 pMDI	CHF 1535 pMDI
	Number of subjects	354	357	357
	FEV1 AUC0-12h Adj. mean Change from Baseline	0.146	0.167	0.062
	(95% CI)	(0.136; 0.157)	(0.156; 0.177)	(0.051; 0.072)
	Trough FEV1 (L) at 24 hours on Day 28 Adj. mean Change from Baseline	-0.006	-0.009	-0.063
	(95% CI)	(-0.019; 0.006)	(-0.021; 0.003)	(-0.076; -0.051)
	Pre-dose morning FEV1 (L) on Day 28 Adj. mean Change from Baseline	0.047	0.056	-0.025
	(95% CI)	(0.034; 0.060)	(0.043; 0.069)	(-0.038; -0.012)
Effect estimate per comparison	Co-Primary endpoint FEV1 AUC0-12h (L) on Day 28	Comparison groups	CHF 5993 DPI vs. CHF 5993 pMDI	
		Adj. mean diff.	-0.020	
		(95% CI)	(-0.035; -0.006)	
		p-value	0.007	
	Co-Primary endpoint FEV1 AUC0-12h (L) on Day 28	Comparison groups	CHF 5993 pMDI vs. CHF 1535 pMDI	
		Adj. mean diff.	0.105	
		(95% CI)	(0.090; 0.120)	
		p-value	< 0.001	
	Co-Primary endpoint FEV1 AUC0-12h (L) on Day 28	Comparison groups	CHF 5993 DPI vs. CHF 1535 pMDI	
		Adj. mean diff.	0.085	
		(95% CI)	(0.070; 0.099)	
		p-value	< 0.001	
Co-Primary endpoint trough FEV1 (L) at 24 hours on Day 28	Comparison groups	CHF 5993 DPI vs. CHF 5993 pMDI		
	Adj. mean diff.	0.003		
	(95% CI)	(-0.015; 0.020)		
	p-value	0.749		
Co-Primary	Comparison groups	CHF 5993 pMDI vs. CHF 1535 pMDI		

	endpoint trough FEV1 (L) at 24 hours on Day 28	Adj. mean diff.	0.054	
		(95% CI)	(0.037; 0.072)	
		p-value	< 0.001	
	Co-Primary endpoint trough FEV1 (L) at 24 hours on Day 28	Comparison groups	CHF 5993 DPI vs. CHF 1535 pMDI	
		Adj. mean diff.	0.057	
		(95% CI)	(0.040; 0.074)	
	Pre-dose morning FEV1 (L) on Day 28	Comparison groups	CHF 5993 DPI vs. CHF 5993 pMDI	
		Adj. mean diff.	-0.009	
		(95% CI)	(-0.027; 0.010)	
	Pre-dose morning FEV1 (L) on Day 28	Comparison groups	CHF 5993 pMDI vs. CHF 1535 pMDI	
		Adj. mean diff.	0.081	
		(95% CI)	(0.062; 0.099)	
Pre-dose morning FEV1 (L) on Day 28	Comparison groups	CHF 5993 DPI vs. CHF 1535 pMDI		
	Adj. mean diff.	0.072		
	(95% CI)	(0.053; 0.090)		
	p-value	< 0.001		
	Notes	N/A		
	Analysis description	N/A		

2.6.5.2. Supportive study

Results of a flow profiling and handling study with the NEXT DPI device (which is the same device as the one presented in this application) has been provided (Study CP01-NEXT DPI). In this study,

- all patients with asthma (in all age categories, including children 5-11 years old) and COPD, irrespective of disease severity (moderate or severe), were able to activate the NEXT DPI breath actuated mechanism.

- the mean PIF measured with the In-Check Dial device was similar in all patients categories, irrespective of diagnosis, age (including children 5-11 years old) and disease severity (moderate or severe), and it was greater than the threshold required for activating the NEXT DPI BAM, thus confirming that all patients were able to generate an inspiratory flow sufficient for the device activation.

- the results of the NEXT DPI usability evaluation questionnaire showed that most of the patients in all of the categories were successfully trained and able to use the device correctly.

2.6.6. Discussion on clinical efficacy

The applicant has submitted a single PD study (Study CLI-05993BA1-02; TRI-D) to support this line extension application and to demonstrate the clinical equivalence of novel Trydonis (BDP/FF/GB) DPI formulation administered via the NEXThaler device to the Trydonis pMDI product already authorised for the treatment of adult patients with moderate to severe COPD. The indication sought is in line with the authorised pMDI formulation.

The new device proposed (Trydonis DPI) is only for use in the COPD indication.

The TRI-D study was designed to specifically address any potential PK difference in BDP (via the measure of trough FEV1 at 24 hours on Day 28) and bronchodilator components FF and GB between Trydonis DPI and Trydonis pMDI (measuring the FEV1 AUC0-12h on Day 28), in line with the CHMP SA received (EMA/H/SA/3068/1/2015/III, EMA/CHMP/SAWP/432923/2017).

Design and conduct of clinical studies

Study design

The study was a double-blind, double-dummy, active-controlled, 3-way cross-over study in patients with moderate to severe COPD. The study included a 2-week run-in period in which subjects were treated with CHF1535 pMDI (Foster) (100/6 µg, 2 puffs BID -total daily dose: 400/24 µg BDP/FF) with patients also receiving this treatment during the 2-week washout periods. Subjects were randomised to receive one of CHF 5993 DPI 100/6/12.5 µg; CHF 5993 pMDI 100/6/12.5 µg, both 2 puffs BID (total daily dose: 400/24/50 µg BDP/FF/GB); or CHF 1535 pMDI 100/6 µg, 2 puffs BID (total daily dose: 400/24 µg BDP/FF).

Due to the fact that it is not possible to demonstrate the differential bronchodilator contribution of the LABA or the LAMA between the Trydonis DPI and Trydonis pMDI based on FEV1 AUC0-12h on Day 28, as the two bronchodilators were administered simultaneously, the dual combination of BDP/FF Foster was added as active comparator.

Subjects included in the trial had a diagnosis of COPD for at least 12 months prior to screening, a post bronchodilator FEV1 $\geq 30\%$ and $< 80\%$ of the predicted normal value and FEV1/FVC < 0.7 , and a smoking history of at least 10 pack years. These patients represent a less severe population with less post bronchodilator airflow limitation relative to the population included in the original pivotal studies (Triple 5-8, FEV1 % of predicted normal value post-bronchodilator $< 50\%$). However, for the purpose of a non-inferiority comparison this is considered acceptable.

Subjects were not required to have experienced an exacerbation in the last 12 months, though those experiencing a moderate or severe exacerbation up to 6 weeks prior to screening were excluded.

The study aimed to demonstrate non-inferiority of the DPI formulation relative to the authorised pMDI formulation in terms of change from baseline FEV1 AUC (0-12h) normalised by time and trough FEV1 24 hours following last dose on day 28. The EMAs 'Guideline on the requirements for clinical documentation for orally inhaled products (OIP) including the requirements for demonstration of therapeutic equivalence between two inhaled products for oral use in the treatment of asthma and chronic obstructive pulmonary disease (COPD) in adults and for use in the treatment of asthma in children and adolescents' (Doc. Ref. CPMP/EWP/4151/00 Rev. 1) states that for FDC products with a reference product, the study should be designed to demonstrate equivalence for each of the components of the fixed-dose combination product.

The applicant stated that the change from baseline FEV1 AUC (0-12h) normalised by time and trough FEV1 at 24 hours on day 28 aim to assess the equivalence of the LAMA/LABA (bronchodilator) and ICS components respectively.

The applicant has justified the study duration on the basis of clinically significant lung function changes observed following 4-weeks treatment with the Trydonis pMDI in the Triple 5 study which were maintained for 52 weeks. Thus, the selection of a 4-week treatment duration for the TRI-D clinical study is considered to be appropriate by CHMP.

It is noted, that these co-primary endpoints and approach have previously been agreed in CHMP scientific follow-up advice (EMA/CHMP/SAWP/432923/2017).

Treatments

The study included a 2-week run in period in which patients were administered CHF 1535 100/6 µg pMDI administered as 2 puffs BID which corresponded to a total daily dose of BDP/FF 400/24 µg.

Following the run-in period, patients were randomised to receive a particular sequence; CHF 5993 DPI 100/6/12.5 µg; CHF 5993 pMDI 100/6/12.5 µg, both 2 puffs BID (total daily dose: 400/24/50 µg BDP/FF/GB); or CHF 1535 pMDI 100/6 µg, 2 puffs BID (total daily dose: 400/24 µg BDP/FF). Salbutamol (100 µg) or terbutaline were available as rescue medication if needed, with only salbutamol used in the trial.

Upon request from the CHMP, the applicant provided a summary of the use of salbutamol rescue medication within 6 hours of spirometry measures. As these were included as major deviations and hence excluded from the PP analysis set in which results were comparable with the ITT analysis for the co-primary endpoints, CHMP considered that rescue medication use during spirometry measurements did not have a significant impact on results.

The applicant has also provided an overview of medication use in subjects with COPD exacerbations during the treatment or washout periods. There was a slightly higher incidence of exacerbations during the treatment periods in the two triple combination groups relative to the BDP/FF pMDI group. The mean treatment duration with systemic corticosteroids ranged from 2.9 to 5 days. The applicant argued that given the short duration of such therapies and the relatively low incidence of COPD exacerbations these were unlikely to have impacted on the results of the completed study. To further support this the applicant presents additional post-hoc analyses of the co-primary endpoints excluding subjects which experienced a COPD exacerbation during a given treatment period or in the case of those who experienced an exacerbation during a wash-out period in the subsequent treatment period. These analyses revealed that exclusion of these subjects did not significantly alter the results with the point estimates for the adjusted mean differences comparable with the initial ITT analysis.

Efficacy variables

A hierarchical testing procedure was pre-specified and applied to the primary endpoints. The co-primary endpoints were to demonstrate non-inferiority of the CHF 5993 DPI relative to the authorised pMDI formulation in terms of change from baseline in FEV1 area under the curve between 0 and 12 hours (AUC0-12h) normalised by time on Day 28 and trough FEV1 at 24 hours on Day 28. The non-inferiority margin was set at -50 ml for both endpoints. For FEV1 AUC0-12h this is based on data acquired in studies to support the pMDI initial MAA and is in line with what was previously accepted in the Triple 6 study and thus is considered acceptable. The data to support this margin for trough FEV1 on Day 28 are scarcer, with 0.076-0.1L cited as the usually accepted minimally clinically important difference. This is accepted. Change from baseline in FEV1 AUC0-12h normalised by time is accepted as an appropriate endpoint to determine the equivalence of the combination in terms of lung function.

The key secondary endpoints included a suite of additional lung function measures [change from baseline in pre-dose morning FEV1 (L) on Day 28; change from baseline in FEV1 area under the curve between 0 and 4 hours (AUC0-4h) normalised by time (L) on Day 28; change from baseline in FEV1 AUC0-12h normalised by time (L) on Day 1; change from baseline in peak FEV1 up to 12 hours (L) on Day 28 and Day 1; responder analysis on the change from baseline in pre-dose morning FEV1 response (change from baseline in pre-dose morning FEV1 \geq 100 mL) on Day 28] and change from baseline in SGRQ total score.

Participant flow

449 patients were screened with 366 were randomised to one of the six treatment sequences. The discontinuation rate was low in this study with 90%+ patients completing each of the treatment sequences. The primary reasons for discontinuation were consent withdrawal and AEs. There was one death during the study (with BDP/FF/GB pMDI) which was not considered to be related to the study treatment.

Conduct of the study

The applicant has stated that change was made to the wording of the primary objectives in the CSR relative to those listed in the protocol for clarity, with the addition of 'change from baseline' prior to the two co-primary endpoints. This was made prior to database lock and is considered acceptable. The number of patients with major protocol deviations was low with non-adequate compliance the primary observed deviation.

Baseline data

The majority of recruited subjects were male (58.7%) and were exclusively white. The majority of subjects (65.8%, 30.7% with 1, 3.6% with 2) had not had a COPD exacerbation in the previous year. Patients previously on triple combination (TC) therapy and dual combination therapy (Either ICS/LAMA, ICS/LABA or LAMA/LABA) for the treatment of COPD were permitted inclusion into the study. There were no requirements related to previous dosing with all eligible patients subsequently entering the two-week run-in period with the CHF 1535 pMDI. 34.7 % of patients recruited were on ICS/LABA/LAMA TC and therefore the run-in and wash out periods represent de-escalation of therapy in these patients. A higher proportion of patients originally on TC were randomised into sequence groups in which the CHF 1535 inhaler was the first treatment (sequence CAB and CBA with 41.7 and 44.3% of patients originally on TC respectively, relative to 34.7% average in the ITT population).

The applicant has provided a summary of pre-dose FEV1 values at V1 and V2 in the subset of subjects who were previously on either ICS/LAMA/LABA or LAMA/LABA therapy prior to inclusion in the TRI-D study. These data did not indicate a significant difference in pre-dose FEV1 values in these subjects following the 2-week open-label Foster (ICS/LABA) run in period. A further summary of pre-dose FEV1 at the start of each treatment period (i.e. at the end of each wash-out period) in this sub-population was also presented. While there is a trend for decreased mean pre-dose FEV1 values in this group (particularly in those treated with LAMA/LABA), given the margin of change in the point estimate and the variability in the measure, it is accepted that this is unlikely to be of clinical relevance. These data, along with the reasonably equal distribution of subjects previously treated with triple combination therapy among the treatment sequences are adequate to assuage concerns on potential effects of this approach on the validity of the data generated.

Efficacy data and additional analyses

Primary Efficacy Variables

The applicant considered that non-inferiority of Trydonis DPI vs. Trydonis pMDI has been demonstrated for both primary efficacy variables because the lower bound of the two-sided 95% CI of the adjusted mean difference between treatments was greater than the pre-defined non-inferiority margin of -0.050 L.

Figure 6: Primary efficacy endpoints, ITT and PP populations – TRI-D study

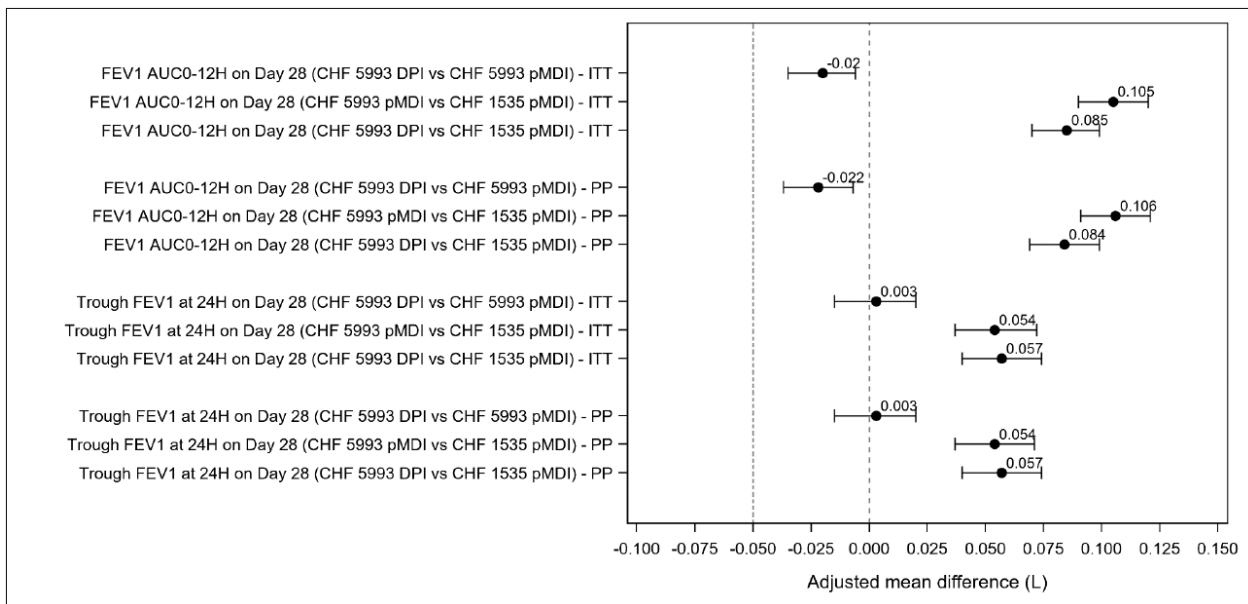

The dotted line at -0.050 L represents the non-inferiority limit.

The superiority of Trydonis pMDI vs. Foster pMDI was tested to demonstrate assay sensitivity (PP population). Assay sensitivity was considered to be established, given the observed statistically significantly greater increase in FEV1 AUC0-12h with Trydonis pMDI vs. Foster pMDI (adjusted mean difference of 0.106 L [95% CI: 0.091; 0.121], $p < 0.001$) and Trydonis DPI vs. Foster pMDI (adjusted mean difference of 0.084 L [95% CI: 0.069, 0.099], $p < 0.001$).

Showing therapeutic equivalence between orally inhaled products based on PD/clinical data is challenging because of difficulties in ensuring assay sensitivity. Assay sensitivity is the ability of a clinical trial to distinguish an effective treatment from a less effective treatment or ineffective treatment. The applicant justified the use of superiority testing of Trydonis pMDI vs. Foster pMDI in terms of FEV1 AUC0-12h normalised by time on Day 28, in order to establish assay sensitivity, based on several considerations (CHF 5993 pMDI and 1535 pMDI are both approved for COPD, they have the same doses of ICS and LABA, there is historical evidence of sensitivity to drug effects and also trial conduct is considered to be appropriate). However, it is still noted that the trial design did not strictly follow the OIP GL requiring investigation of two different dose levels to allow for estimation of assay sensitivity. Nevertheless, taking into account, that the study was conducted to give some reassurance that the differences in Cmax for FF and GB, and the lower exposure of BDP/B17MP are not clinically relevant, the issue was not further pursued by CHMP.

Trough FEV1, measured at 24 hours post-dose was selected to minimise any residual bronchodilator effect of the LABA and LAMA (FF and GB) components of CHF 5993 DPI, allowing to assess the contribution of the ICS component (BDP). The 24-hour washout period post-dose on Day 28 was chosen as a compromise between, on the one hand, the need to limit the potential residual effect of these twice-daily administered LABA (FF) and LAMA (GB) and, on the other hand, the need to limit the period during which patients would have been without daily maintenance treatment (i.e. in order to safeguard the safety of the patients with moderate-severe COPD who may very likely not tolerate an extended maintenance treatment- free period).

There was no change from baseline trough FEV1 at 24 hours on day 28 for either CHF 5993 formulation, whereas a significant decrease in this endpoint was evident in the CHF 1535 group (-0.063 L [95% CI: -0.076; -0.051]). These data suggest a carryover effect for the LAMA component 24

hours post dosing. However, considering the 50-hour half-life of GB, a “true” washout would have required more than 10 days off therapy.

Secondary Efficacy Variables

Secondary endpoints related to a number of additional lung function parameters based of serial spirometry measures and a quality of life assessment based on St. George’s Respiratory Questionnaire as well as a responder analysis and an analysis of rescue treatment free days. Both CHF 5993 formulations resulted in statistically significant improvements relative to CHF 1535 in all lung function measures.

The adjusted mean difference between CHF 5993 DPI and CHF 5993 pMDI was not statistically significant for change from baseline in pre-dose morning FEV1 on day 28, -0.009 L ([95% CI: -0.027; 0.010], p=0.363), in FEV1 AUC(0-12h) on day 1, 0.002 L ([95% CI: -0.011; 0.014], p=0.782), peak FEV1 up to 12 hours on Day 1, -0.002 L ([95% CI: -0.015; 0.011], p=0.742).

There was a statistically significant adjusted mean difference between CHF 5993 DPI and CHF 5993 pMDI in FEV1 AUC0-4h on day 28, -0.026 L [95% CI: -0.043; -0.010] and for in peak FEV1 up to 12 hours on day 28, -0.023 L ([95% CI: -0.040; -0.007], p=0.005) . However, these differences were of small magnitude and thus considered by CHMP to be not clinically relevant.

There was no difference evident between CHF 5993 DPI and CHF 5993 pMDI in percentage of patients classified as FEV1 responders (i.e. change from baseline in pre-dose morning FEV1 \geq 100 mL) on Day 28, odds ratio: 1.029 ([95% CI: 0.690; 1.533], p=0.890).

There was no difference evident between CHF 5993 DPI and CHF 5993 pMDI in decrease in total SGRQ score from baseline (0.43 [95% CI: -0.60; 1.47], p=0.410). Furthermore, it was noted that under the ‘impact’ subdomain related to the psychosocial impact of disease, while the pMDI formulation was associated with a statistically significant improvement (adjusted mean change from baseline -1.10 [-1.97; -0.22]), the CHF 5993 DPI formulation did not (adjusted mean change from baseline -0.57 [-1.44; 0.31]).

There was no difference evident between CHF 5993 DPI and CHF 5993 pMDI in % rescue medication free days, 1.64% [95% CI: -0.61; 3.89], p=0.154).

Overall, CHMP considered that secondary endpoints were sufficient to support the non-inferiority of the DPI formulation relative to the pMDI product in terms of lung function. In addition, CHMP considered that these endpoints again are a measure of bronchodilatory LAMA/LABA induced effects.

2.6.7. Conclusions on the clinical efficacy

The submitted efficacy study (TRI-D) met its co-primary endpoints and could be considered sufficient to conclude the non-inferiority of the novel DPI product in terms of LAMA/LABA induced bronchodilatory effect relative to the authorised Trydonis pMDI in this patient population. While PK is more sensitive than PD to discriminate differences in inhaler formulation, results of the TRI-D efficacy study gave some reassurance that the differences in C_{max} for FF and GB, and the lower exposure of BDP/B17MP are overall not clinically relevant. The CHMP considered that CHF 5993 DPI can be approved in COPD from a clinical efficacy viewpoint.

2.6.8. Clinical safety

This section presents the safety results obtained in the TRI-D study (CLI-05993BA1-02) conducted in patients with moderate to severe COPD carried out as part of the clinical development programme for

BDP/FF/GB DPI only. Safety results obtained in the PK study (CCD-05993BA1-01) conducted in healthy subjects were also presented in this application.

2.6.8.1. Patient exposure

In the TRI-D study, the majority of patients completed treatment as planned per protocol with twenty-four (24) (6.6%) patients discontinuing the study overall. The mean duration of exposure to total daily doses of BDP/FF/GB DPI, BDP/FF/GB pMDI and BDP/FF pMDI was comparable (28.9, 28.6 and 28.7 days, respectively).

Table 18: Duration of exposure – TRI-D study

	BDP/FF/GB DPI	BDP/FF/GB pMDI	BDP/FF pMDI
Number of patients in Safety population	354	358	357
Days	28.9 (1.8)	28.6 (3.3)	28.7 (2.7)
Mean (SD) Range	15 ; 50	1 ; 45	1 ; 43

2.6.8.2. Adverse events

In the TRI-D study, a total of seventy two (72), eighty eight (88) and sixty seven (67) TEAEs were reported in fifty five (55) (15.5%), sixty seven (67) (18.7%) and fifty five (55) (15.4%) patients with BDP/FF/GB DPI, BDP/FF/GB pMDI and BDP/FF pMDI, respectively. The majority of TEAEs were mild or moderate in intensity.

The overall incidence of ADRs was low and comparable among treatments. Fifteen (15) treatment-emergent ADRs were reported in twelve (12) (3.3%) patients. By treatment, four (4), four (4) and seven (7) ADRs were reported in three (3) (0.8%), 3 (0.8%) and seven (7) (2.0%) patients with BDP/FF/GB DPI, BDP/FF/GB pMDI and BDP/FF pMDI, respectively (

Table **25**).

With all treatments, the majority of treatment-emergent ADRs by PT were reported in one (1) patient only; the only ADR reported in > 1 patient with any treatment was dry mouth, in two (2) (0.6%) patients with BDP/FF/GB DPI and one (1) (0.3%) patient with BDP/FF pMDI. No ADRs of dry mouth were reported with BDP/FF/GB pMDI.

All but one of the events were mild to moderate in intensity and the majority were resolved by the end of the study. None of the ADRs were considered serious.

Table 19: All treatment-emergent ADRs by SOC and PT, Safety population – TRI-D study

SOC, PT	BDP/FF/GB DPI		BDP/FF/GB pMDI		BDP/FF pMDI		Overall N=36	
	Events	n (%)	Events	n (%)	Events	n (%)	Events	n (%)
At least 1 ADR	4	3 (0.8)	4	3 (0.8)	7	7 (2.0)	15	12 (3.3)
Gastrointestinal disorders	2	2 (0.6)	0	0 (0.0)	2	2 (0.6)	4	4 (1.1)
Dry mouth	2	2 (0.6)	0	0 (0.0)	1	1 (0.3)	3	3 (0.8)
Constipation	0	0 (0.0)	0	0 (0.0)	1	1 (0.3)	1	1 (0.3)
Respiratory, thoracic and mediastinal disorders	1	1 (0.3)	1	1 (0.3)	1	1 (0.3)	3	3 (0.8)
Cough	1	1 (0.3)	1	1 (0.3)	0	0 (0.0)	2	2 (0.5)
Dysphonia	0	0 (0.0)	0	0 (0.0)	1	1 (0.3)	1	1 (0.3)
Cardiac disorders	0	0 (0.0)	0	0 (0.0)	2	2 (0.6)	2	2 (0.5)
Supraventricular extrasystoles	0	0 (0.0)	0	0 (0.0)	1	1 (0.3)	1	1 (0.3)
Tachycardia	0	0 (0.0)	0	0 (0.0)	1	1 (0.3)	1	1 (0.3)
General disorders and administration	0	0 (0.0)	1	1 (0.3)	1	1 (0.3)	2	2 (0.5)
General physical health deterioration	0	0 (0.0)	1	1 (0.3)	0	0 (0.0)	1	1 (0.3)
Non-cardiac chest pain	0	0 (0.0)	0	0 (0.0)	1	1 (0.3)	1	1 (0.3)
Nervous system disorders	0	0 (0.0)	2	2 (0.6)	0	0 (0.0)	2	2 (0.5)
Dizziness	0	0 (0.0)	1	1 (0.3)	0	0 (0.0)	1	1 (0.3)
Headache	0	0 (0.0)	1	1 (0.3)	0	0 (0.0)	1	1 (0.3)
Infections and infestations	1	1 (0.3)	0	0 (0.0)	0	0 (0.0)	1	1 (0.3)
Oral fungal infection	1	1 (0.3)	0	0 (0.0)	0	0 (0.0)	1	1 (0.3)
Investigations	0	0 (0.0)	0	0 (0.0)	1	1 (0.3)	1	1 (0.3)
Electrocardiogram QT prolonged	0	0 (0.0)	0	0 (0.0)	1	1 (0.3)	1	1 (0.3)

Overall, Trydonis DPI was safe and well-tolerated, and did not differ significantly from the approved drug products (Trydonis pMDI, Foster pMDI) if administered to in patients with moderate to severe COPD for 4 weeks. No new and/or unexpected clinical findings were observed.

2.6.8.3. Serious adverse event and deaths

In the TRI-D study, the incidence of serious TEAEs was similar among treatments: six (6) serious TEAEs were reported in four (4) (1.1%) patients with BDP/FF/GB DPI, nine (9) serious TEAEs were reported in six (6) (1.7%) patients with BDP/FF/GB pMDI and one (1) serious TEAE was reported in one (1) (0.3%) patient with BDP/FF pMDI. None of these events were considered related to the study treatment (i.e. none were serious ADRs). One (1) TEAE led to death (PT: pulmonary haemorrhage) with BDP/FF/GB pMDI. This event was not considered to be related to the study treatment.

2.6.8.4. Laboratory findings

In the TRI-D study, for all haematology and blood chemistry parameters, the vast majority of subjects presented normal or abnormal non-clinically significant (NCS) values at screening and on Day 28 of the last treatment period. No new CS abnormalities in haematology parameters not already present at screening were observed on Day 28 of the last treatment period and reported as TEAEs. Of note, CS abnormalities in blood chemistry parameters observed on Day 28 of the last treatment period (but normal or abnormal NCS at screening) were reported as TEAEs in five (5) patients (PTs: hyperglycaemia, renal impairment, hepatic steatosis, blood potassium increased and liver function test increased). None of the events were considered to be related to study treatment.

2.6.8.5. Safety in special populations

No safety data in special populations were submitted for the DPI formulation of CHF 5993 in this application.

2.6.8.6. Safety related to drug-drug interactions and other interactions

No safety data related to drug-drug interactions and/or other interactions were submitted for the DPI formulation of CHF 5993 in this application

2.6.8.7. Discontinuation due to adverse events

In the TRI-D study, the incidence of TEAEs leading to study treatment discontinuation was comparable among treatments, with four (4) events leading to discontinuation in 1 (0.3%) patient with BDP/FF/GB DPI, seven (7) events leading to discontinuation in five (5) (1.4%) patients with BDP/FF/GB pMDI and one (1) event leading to discontinuation in one (1) (0.3%) patient with BDP/FF pMDI. There was one (1) ADR (PT: non-cardiac chest pain) which led to permanent discontinuation of study treatment reported during treatment with BDP/FF pMDI. No ADRs leading to permanent discontinuation of study treatment were reported with BDP/FF/GB DPI or BDP/FF/GB pMDI.

2.6.8.8. Post marketing experience

No post-marketing data are available for Trydonis DPI.

2.6.9. Discussion on clinical safety

Trydonis pMDI has already a marketing authorisation for the indication chronic obstructive pulmonary disease (COPD) since 2017. Thus, the safety profile has already been established for the COPD population. Safety results obtained in the PK study (CCD-05993BA1-01) conducted in healthy subjects and the TRI-D study (CLI-05993BA1-02) conducted in patients with moderate to severe COPD carried out as part of the clinical development programme for BDP/FF/GB DPI have been presented.

In the PK study, Trydonis DPI was safe and well-tolerated, and did not differ significantly from the approved medicinal product (Trydonis pMDI) if administered to healthy volunteers of both gender at the same suprathapeutic dosage.

In the TRI-D study, no new and/or unexpected clinical findings were observed. Incidence of TEAEs and results of further safety variables (incl. routine laboratory safety, vital signs and 12-lead ECG

monitoring) were comparable between Trydonis DPI and the approved medicinal products (Trydonis pMDI, Foster pMDI).

From a safety perspective, a major limitation is the short duration of exposure in the Phase 2 study – 28 days across the three arms but also the 3-way cross-over randomised design which limits the interpretation of the safety data. Each 4-week treatment period was separated by a 2-week (\pm 2 days) wash-out period, during which patients received CHF 1535 pMDI 100/6 μ g as during the run-in.

In light of the short study duration and the PK exposure results for the LABA and LAMA components demonstrating transient differences in C_{max} between the two products, a post authorisation safety study is being proposed by the applicant which will primarily focus on MACE incidences as the primary objective to assess the long-term effects of the new formulation DPI. This approach is supported and details of the PASS have been outlined in the RMP Annex 3.

The TEAEs reported in the TRI-D study > 1% of patients with any treatment were COPD exacerbation, nasopharyngitis, headache and back pain. The TEAEs presented are expected with this combination and disease type. There were no major differences in AEs between the type of inhaler used.

All the ADRs observed with CHF 5993 DPI (dry mouth, oral fungal infection and cough) are in line with the known safety profile of the approved CHF 5993 pMDI. These ADRs are captured in the SmPC section 4.8 as well as in section 4 of the patient leaflet.

Upon review of the non-cardiac chest pain narrative that led to treatment discontinuation in the BDP/FF MDI arm, it appeared that this non-serious ADR resolved without intervention after a couple of days. There were no events of cardiac disorders reported as a TEAE in the DPI formulation group during the study.

Six SAEs were reported in four patients in the DPI group: pneumonia, GI infection, chronic pancreatitis, rib & patellar fractures & pneumothorax. None were considered treatment related and one of the patients discontinued treatment. While there are no SAEs presented that demonstrate a concern for the DPI, the non-inferiority study is too short to be conclusive especially for capturing MACE as these were not assessed specifically. The PASS study should adequately address this concern. The main rationale to suggest a PASS in the 2017 follow-up CHMP SA, was to collect further reassurance on the therapeutic equivalence between the pMDI and the DPI formulations of Trimbrow and to address the long-term LAMA safety exposure. Furthermore, it was emphasised that the hypothesis on which the sample size will be based on (in particular the proposed Major Adverse Cardiovascular Events incidence rate) should be clearly justified and referenced. A consistent definition of MACE from previous PASS was also advised to be followed. It is noted that all-cause mortality has been included as a secondary objective of the PASS. The PASS protocol is planned to be submitted for PRAC assessment by 31 May 2021 as reflected in the RMP.

As discussed above, MACE were not captured as a specific endpoint in the 4 week non-inferiority study but will be assessed in the PASS. Patients with significant cardiovascular disease and arrhythmias were excluded from the non-inferiority study and safety data for patients who had cardiovascular risk factors were not presented specifically (high BMI, hypertension, diabetes mellitus etc). These issues should be addressed in the PASS given how the patient population will reflect the real-world setting.

Furthermore, the one death that occurred was not in the DPI arm but rather the BDP/FF/GB pMDI arm. Upon review of the death narrative for pulmonary haemorrhage, this occurred suddenly without cardiac or respiratory symptoms preceding the event. Asphyxiation caused by a massive pulmonary haemorrhage was recorded however an autopsy report was not performed. Upon request by CHMP, the applicant has presented the case history of the patient that died in the BDP/FF/GB MDI arm, however, a death certificate is unavailable. The Applicant considered that this event was not related to the study treatment. This could be agreed.

Based on the safety results presented from the TRI-D study, there is currently no trend to suggest a negative benefit risk for safety however as previously highlighted this study has some limitations; long term data is required to fully characterise the PK results and identify any negative impact on the safety profile of Trydonis DPI.

2.6.10. Conclusions on the clinical safety

Based on the safety results presented in this application, there were no emerging safety signals however the short duration of treatment and follow up limited the assessment. In light of the higher exposure demonstrated in the PK study for both the LABA and LAMA components in the DPI formulation, the PASS study should adequately address this in the context of long-term exposure and capturing MACE.

Overall, CHMP concluded that Trimbow DPI was approvable from a clinical safety viewpoint.

2.7. Risk Management Plan

2.7.1. Safety concerns

Summary of safety concerns	
Important identified risks	None
Important potential risks	Cardio-and cerebrovascular events
Missing information	None

2.7.2. Pharmacovigilance plan

Study/Status	Summary of objectives	Safety concerns addressed	Milestones	Due dates
Category 3 - Proposed additional pharmacovigilance activities				
Multinational database cohort study Proposed	<p>Primary Objective: The primary objective of this study will be to assess the incidence of MACEs, defined as any of the following events:</p> <ul style="list-style-type: none"> • Myocardial infarction • Stroke (ischemic and haemorrhagic stroke) • Hospitalization due to acute coronary syndrome • Hospitalization due to heart failure <p>Secondary Objectives: The secondary objectives of the study will be to assess separately the incidence of each of the following specific events:</p> <ul style="list-style-type: none"> • Myocardial infarction • Cerebrovascular disorders (ischemic and haemorrhagic stroke, transient ischemic attack) • Hospitalization due to acute coronary syndrome • Hospitalization due to heart failure • Arrhythmias (new-sustained supraventricular and sustained ventricular) • All-cause death 	The main aim of the study is to assess adverse cardiovascular and cerebrovascular outcomes in COPD patients which are new users of Trimbow administered via DPI compared to new users of Trimbow administered via pMDI.	Protocol submission	31 May 2021
			Final report	Within 12-months from End of data collection

The proposed PASS study is related to the long-term use of Trimbow DPI vs Trimbow pMDI and addresses the important potential risk of cardio and cerebrovascular events. As such, this non-interventional study will primarily assess the incidence of MACE among new users of Trimbow DPI vs. Trimbow pMDI.

The conduction of this PASS is also acceptable for Trydonis.

2.7.3. Risk minimisation measures

Safety concern	Routine risk minimisation measures	Pharmacovigilance activities
Cardio- and cerebrovascular events	<ul style="list-style-type: none"> - Statement in section 4.4 and labelled in section 4.8 of the SmPC - Statement in section 2 and in section 4 of the PL 	<ul style="list-style-type: none"> - Routine PhV activities - Additional pharmacovigilance activities: PASS study

2.7.4. Conclusion

The CHMP and PRAC considered that the risk management plan version 8.1 is acceptable.

2.8. Pharmacovigilance

2.8.1. Pharmacovigilance system

The CHMP considered that the pharmacovigilance system summary submitted by the MAH fulfils the requirements of Article 8(3) of Directive 2001/83/EC.

2.8.2. Periodic Safety Update Reports submission requirements

The requirements for submission of periodic safety update reports for this medicinal product are set out in the list of Union reference dates (EURD list) provided for under Article 107c(7) of Directive 2001/83/EC and any subsequent updates published on the European medicines web-portal.

2.9. Product information

2.9.1. User consultation

The results of the user consultation with target patient groups on the package leaflet submitted by the MAH show that the package leaflet meets the criteria for readability as set out in the *Guideline on the readability of the label and package leaflet of medicinal products for human use*.

3. Benefit-Risk Balance

3.1. Therapeutic Context

3.1.1. Disease or condition

COPD is a progressive disease characterised by increasing obstruction to airflow and the progressive development of respiratory symptoms including chronic cough, increased sputum production, dyspnoea and wheezing. The objective of pharmacological treatment is to prevent and control symptoms, reduce the frequency and severity of exacerbations, and improve general health status and exercise tolerance.

Smoking cessation (including passive smoking) is extremely important. Ideally treatment of COPD would slow its progression but this has never been convincingly demonstrated. Long term domiciliary oxygen has been shown to prolong life but confines the patient to home for protracted periods. In recent years there has been increasing emphasis on physical training and rehabilitation. Moderate and severe COPD exacerbations are generally treated with antibiotics and oral corticosteroids. Maintenance treatment is by combinations of oral and inhaled bronchodilators and anti-inflammatory agents.

3.1.2. Available therapies and unmet medical need

The Global Initiative for Chronic Obstructive Lung Disease (GOLD) document recommends the use of one or more long-acting bronchodilators as maintenance therapy for the treatment and management of COPD [GOLD, 2020¹²]. ICS are highly effective as anti-inflammatory treatments in respiratory diseases and maintenance treatment with ICS is routinely used in association with LABAs for patients with a history of exacerbations despite treatment with long-acting bronchodilators. Such ICS/LABA combinations may be the first choice of initial therapy in some patients, such as those with a history and/or finding suggestive of asthma-COPD overlap syndrome (ACOS) [GINA, 2019¹³].

The triple combination therapy of inhaled ICS, LABA and LAMA, has become an option for maintenance treatment of COPD and as a "step-up" therapy from double therapies, when patients remain symptomatic with dual therapies (as a rational escalation of pharmacological management).

3.1.3. Main clinical studies

The clinical development programme included two studies:

- One PK, single supra-therapeutic dose study in healthy adults (hereafter also referred to as PK study; CCD-05993BA1-01);
- One Phase II, repeat therapeutic dose study in adult patients with moderate to severe COPD (hereafter also referred to as TRI-D study; CLI-05993BA1-02).

3.2. Favourable effects

Pharmacokinetics

¹² Global Initiative for Chronic Obstructive Lung Disease (GOLD): global strategy for the diagnosis, management and prevention of COPD. 2020 update. Available at: www.goldcopd.org.

¹³ Global Initiative for Asthma (GINA): global strategy for asthma management and prevention. 2019 update. Available at: www.ginasthma.org.

To support the clinical development of Trydonis DPI, a PK study to investigate the test product (Trydonis DPI) in two different formulations (Formulation 1 and Formulation 2) and to identify a DPI formulation with the most comparable PK profile to Trydonis pMDI was conducted. Both total systemic exposure (without charcoal block, CB) and pulmonary deposition (with charcoal block, CB) were evaluated. Among the two tested formulations of Trydonis DPI, the one referred to as Formulation 2 shows the most comparable PK profiles to Trydonis pMDI.

However, formulation 2 does not show a fully comparable PK profile for the different active components. The total systemic exposure of the FF (C_{max} Ratio T2 vs. R1/R1R 161.56 [90% CI 142.88; 182.68]; AUC_{0-t} Ratio T2 vs. R1/R1R 122.32 [90% CI 113.43; 131.91]) and GB (C_{max} Ratio T2 vs. R1/R1R 223.84 [90% CI 189.04; 265.04]) components as a surrogate for safety were substantially higher with Trydonis DPI as compared to Trydonis pMDI without Spacer, while the pulmonary deposition of the active metabolite of BDP (B17MP) (C_{max} Ratio T2 vs. R1/R1R 86.55 [90% CI 74.24; 100.91]) component as a surrogate for efficacy was lower (for the peak concentration only) with Trydonis DPI as compared to the Trydonis pMDI without Spacer.

When comparing formulation 2 and Trydonis pMDI with Spacer, the total systemic exposure of GB (C_{max} Ratio T2 vs. R2 127.38 [90% CI 105.31; 154.07]) component only was higher with Trydonis DPI.

Effects on lung function

Non-inferiority of Trydonis DPI vs. Trydonis pMDI is claimed for both primary efficacy variables FEV₁, AUC_{0-12h} on Day 28 and trough FEV₁ at 24 hours on Day 28, because the lower bound of the two-sided 95% CI of the adjusted mean difference between treatments was greater than the pre-defined non-inferiority margin of -0.050 L. Assay sensitivity (based on PP population) was considered to be established, given the observed statistically significantly greater increase in FEV₁ AUC_{0-12h} with Trydonis pMDI vs. Foster pMDI (adjusted mean difference of 0.106 L [95% CI: 0.091; 0.121], $p < 0.001$) and Trydonis DPI vs. Foster pMDI (adjusted mean difference of 0.084 L [95% CI: 0.069, 0.099], $p < 0.001$).

The effect of 28 days treatment with either the DPI or pMDI formulations were also compared via number of other lung function measures derived from the same serial spirometry assessments with no statistically or clinically significant differences between the two products noted.

Overall, this study included lung function co-primary endpoints and is considered to have adequately demonstrated non-inferiority of the CHF 5993 DPI relative to the authorised pMDI formulation in terms of change from baseline in FEV₁ area under the curve between 0 and 12 hours (AUC_{0-12h}) normalised by time on Day 28 and trough FEV₁ at 24 hours on Day 28. Both these endpoints are considered to assess the comparative bronchodilatory activity of the two products over the study treatment period which will primarily relate to the LAMA and LABA components.

3.3. Uncertainties and limitations about favourable effects

Showing therapeutic equivalence between orally inhaled products based on PD/clinical data is challenging because of difficulties in ensuring assay sensitivity. The applicant justified the use of superiority testing of Trydonis pMDI vs. Foster pMDI in terms of FEV₁ AUC_{0-12h} normalised by time on Day 28, in order to establish assay sensitivity, based on several considerations (CHF 5993 pMDI and 1535 pMDI are both approved for COPD, they have the same doses of ICS and LABA, there is historical evidence of sensitivity to drug effects and also trial conduct is considered to be appropriate). However, it is still noted that the trial design does not follow strictly the OIP GL requiring investigation of two different dose levels to allow for estimation of assay sensitivity. Nevertheless, taking into account, that

the study was conducted to give some reassurance that the differences in C_{max} for FF and GB, and the lower exposure of BDP/B17MP are not clinically relevant, the issue was not further pursued by CHMP.

There was no change from baseline trough FEV₁ at 24 hours on day 28 for either CHF 5993 formulation, whereas a significant decrease in this endpoint was evident in the CHF 1535 group (-0.063 L [95% CI: -0.076; -0.051]). These data suggest a carryover effect for the LAMA component 24 hours post dosing. However, considering the 50-hour half-life of GB, a “true” washout would have required more than 10 days off therapy.

3.4. Unfavourable effects

The safety profile of Trydonis in COPD is well understood; none of the active substances is a new active substance and all have been used over periods of at least years individually and in combination in treating COPD patients of various grades of severity. To date, about 3400 patients have been treated in clinical trial with the triple combination (counting the free and fixed combinations) many of them for 52 weeks.

The TEAEs reported in the TRI-D study > 1% of patients with any treatment were COPD exacerbation, nasopharyngitis, headache and back pain. The TEAEs presented are expected with this combination and disease type. There were no major differences in AEs between the type of inhaler used.

All the ADRs observed with CHF 5993 DPI (dry mouth, oral fungal infection and cough) are in line with the known safety profile of the approved CHF 5993 pMDI. These ADRs are captured in the SmPC and patient leaflet.

Six SAEs were reported in four patients in the DPI group: pneumonia, GI infection, chronic pancreatitis, rib & patellar fractures & pneumothorax. None were considered treatment related and 1 of the patients discontinued treatment.

Upon review of the non-cardiac chest pain narrative that led to treatment discontinuation in the BDP/FF MDI arm, this non-serious ADR resolved without intervention after a couple of days. There were no events of cardiac disorders reported as a TEAE in the DPI formulation group during the study.

Overall, based on the safety results presented from the TRI-D study, there is currently no trend to suggest a negative benefit risk for safety however as previously highlighted this study has some limitations; long term data is required to fully characterise the PK results and confirm whether those might have any negative impact on the safety profile of Trimbow DPI. In light of the higher exposure demonstrated in the PK study for both the LABA and LAMA components in the DPI formulation, the PASS study should adequately address this in the context of long-term exposure and capturing MACE.

3.5. Uncertainties and limitations about unfavourable effects

While there are no SAEs presented that demonstrate a concern for the DPI, the non-inferiority safety study is too short to be conclusive on the safety of the new device especially for capturing MACE as these were not assessed specifically. The PASS study, that is planned to be performed by the applicant, should adequately address this concern.

MACE were not captured as a specific endpoint in the 4 week non-inferiority study but will be assessed in the PASS. Patients with significant cardiovascular disease and arrhythmias were excluded from the non-inferiority study and safety data for patients who had cardiovascular risk factors were not presented specifically (high BMI, hypertension, diabetes mellitus etc). These issues should be addressed in the PASS given how the patient population will reflect the real-world setting.

3.6. Effects Table

Not applicable.

3.7. Benefit-risk assessment and discussion

3.7.1. Importance of favourable and unfavourable effects

The aim of the submitted studies was to establish the therapeutic equivalence of the novel CH 5993 DPI product relative to the authorised CHF 5993 pMDI product (Trydonis). The MAH conducted a single dose PK study in healthy patients to investigate formulation related differences in lung disposition of each of the mono-components of this triple FDC product and to choose the formulation with the most comparable PK.

The results of PK Study CCD-05993BA1-01 showed that none of the mono-components of the CHF 5993 DPI formulation chosen for the to be marketed DPI product are bioequivalent with those of the authorised Trydonis pMDI product.

Data from this study indicated that the DPI product is associated with higher systemic absorption following administration with charcoal block (i.e. a more sensitive measure of lung disposition) of the LAMA and LABA components relative to the authorised pMDI product (GB, 2.9-fold increase in C_{max} and a 1.2 fold increase in AUC_{0-t} ; FF, 1.8 fold increase in C_{max} and AUC_{0-t}). For ICS metabolite B17MP, the DPI product is associated with a slightly lower C_{max} following administration with charcoal block relative to the authorised pMDI product (86.55 [95% CI 74.24; 100.91]), whereas for AUC_{0-t} , the 90% CI are contained within the bioequivalence range (107.61 [95% CI 95.18, 121.66]). As AUC_{0-t} is considered the most relevant PK measure associated with ICS efficacy it is accepted for this line-extension application that while not bioequivalent for C_{max} , the PK of the two products for the ICS component are essentially comparable in terms of AUC_{0-t} and therefore efficacy is anticipated to be also comparable.

Nevertheless, as bioequivalence in terms of C_{max} could not be established the MAH undertook an additional phase II study to assess the comparative safety and efficacy of the DPI product relative to the authorised pMDI product in moderate to severe COPD patients (Study CLI-05993BA1-02).

The TRI-D study was designed to specifically address any potential PK difference in BDP (via the measure of trough FEV1 at 24 hours on Day 28) and bronchodilator components FF and GB between Trydonis DPI and Trydonis pMDI (measuring the FEV1 AUC_{0-12h} on Day 28), in line with advice received from the CHMP/SAWP. It is noted, a study that would target the contribution of each single active ingredient, especially when two bronchodilators will be administered simultaneously, is quite challenging. On the other hand, the contribution of each component to the overall effect of Trydonis has been sufficiently studied during the development of the pMDI without the need to be reassessed.

This study included lung function co-primary endpoints and is considered to have adequately demonstrated non-inferiority of the CHF 5993 DPI relative to the authorised pMDI formulation in terms of change from baseline in FEV1 area under the curve between 0 and 12 hours (AUC_{0-12h}) normalised by time on Day 28 and trough FEV1 at 24 hours on Day 28. Both these endpoints are considered to assess the comparative bronchodilatory activity of the two products over the study treatment period which will primarily relate to the LAMA and LABA components.

Based on the safety results presented from the TRI-D study, there is currently no trend to suggest a negative benefit risk for safety however as previously highlighted this study has some limitations; long term data is required to fully characterise the PK results and confirm whether those might have any

negative impact on the safety profile of Trydonis DPI. In light of the higher exposure demonstrated in the PK study for both the LABA and LAMA components in the DPI formulation, the PASS study should adequately address this in the context of long-term exposure and capturing MACE.

3.7.2. Balance of benefits and risks

Generally, PK is more sensitive than PD to discriminate differences in inhaler formulation. However, results of the TRI-D PD study give some reassurance that differences in C_{max} for FF and GB observed in the PK study, and the lower exposure of BDP/B17MP are not clinically relevant.

The risk benefit is considered demonstrated for COPD patients. The DPI device should not be used in patients with Asthma.

3.7.3. Additional considerations on the benefit-risk balance

Not applicable.

3.8. Conclusions

The overall B/R of Trydonis DPI in COPD is positive.

4. Recommendations

Outcome

Based on the CHMP review of data on quality, safety and efficacy, the CHMP considers by consensus that the benefit-risk balance of, Trydonis new pharmaceutical form (new device - inhalation powder) associated with a new strength (88µg / 5µg / 9µg) is favourable in the following indication:

Maintenance treatment in adult patients with moderate to severe chronic obstructive pulmonary disease (COPD) who are not adequately treated by a combination of an inhaled corticosteroid and a long-acting beta2-agonist or a combination of a long-acting beta2-agonist and a long-acting muscarinic antagonist (for effects on symptoms control and prevention of exacerbations see section 5.1).

Furthermore, the PI is brought in line with the latest QRD template version 10.2.

The CHMP therefore recommends the extension of the marketing authorisation for Trydonis DPI in COPD subject to the following conditions:

Conditions or restrictions regarding supply and use

Medicinal product subject to medical prescription.

Conditions and requirements of the marketing authorisation

Periodic Safety Update Reports

The requirements for submission of periodic safety update reports for this medicinal product are set out in the list of Union reference dates (EURD list) provided for under Article 107c(7) of Directive 2001/83/EC and any subsequent updates published on the European medicines web-portal.

Conditions or restrictions with regard to the safe and effective use of the medicinal product

- **Risk Management Plan (RMP)**

The Marketing authorisation holder (MAH) shall perform the required pharmacovigilance activities and interventions detailed in the agreed RMP presented in Module 1.8.2 of the marketing authorisation and any agreed subsequent updates of the RMP.

An updated RMP should be submitted:

- At the request of the European Medicines Agency;
- Whenever the risk management system is modified, especially as the result of new information being received that may lead to a significant change to the benefit/risk profile or as the result of an important (pharmacovigilance or risk minimisation) milestone being reached.